



Technical Documentation

LAS 260.1

Version 03



Contents

Description of Product Series	3
Features – LAS 260.1 Extraction and Filtration Unit.....	3
Equipment	4
Technical Data – LAS 260.1 MD.20	6
Characteristic Curves and Operating Modes (230 V).....	7
LAS Series – Laser Smoke	8
Areas of Application.....	8
Operating Principle.....	8
Device Variant.....	9
LAS 260.1 MD.20 FK.....	9
Accessory items	10
DN50 extraction system	10
DN80 extraction system	11
DN100 extraction system	12
Interface accessories.....	12
Spark pre-separator.....	12
Secondary filter U15.....	12
Replacement filter	13

Attachments:

- Drawing
- Interface diagram M12



Description of Product Series

The **LAS 260.1** series is used for collection and filtration of dry and non-combustible dusts in air mixtures that are not potentially explosive and are produced during laser machining.

Suitable multi-stage filtration systems are available **for all industrial applications** to deal with different configurations of harmful or unwanted substances.

The harmful and unwanted substances produced in the relevant customer process are collected via collection elements immediately at the point of creation and then filtered by the units in the LAS 260.1 series. Individual filters are carefully combined for the individual application process to achieve the **highest separation rates**. The underlying filtration technology uses particle separation techniques for dusts and adsorption techniques for gaseous substances.

Thanks to the high degree of purification, the filtered clean gas can be directed back to the working space (**recirculated air mode**). As a result there are no thermal losses. If recirculated air mode is not required, the configuration can be changed so that the outlet air is discharged rather than fed back into the process. This can be set up very easily by installing the pipe nozzle that is included with the unit. The filtered clean gas is then directed into an **air outlet** system.

The units in the LAS 260.1 series can be optionally combined with a **wide range of accessories**. Suitable accessory parts can be selected based on the individual requirements of the customer.

Features – LAS 260.1 Extraction and Filtration Unit

- **Interchangeable filter system** – for safe removal with minimal contamination risk
- **Low-cost replacement filters** thanks to multi-stage filtration system with cost-effective pre-filter elements with high absorption capacity
- Suitable for a **wide range of applications**: the blower used is suitable for high vacuums and high volumetric flow rates
- **Low energy consumption** thanks to energy-efficient electronics
- Electrical equipment designed for **global use**: suitable for operation at 110 V - 240 V
- All electrical components compliant with UL and CE standards
- Integrated soundproofing ensures extremely **quiet operation**
- Robust sheet steel enclosure **powder coated**
- **Mobile unit** with casters
- All interfaces are rear-mounted
- Operating and control elements are located on the front





Equipment

Figure 1: Front operating panel

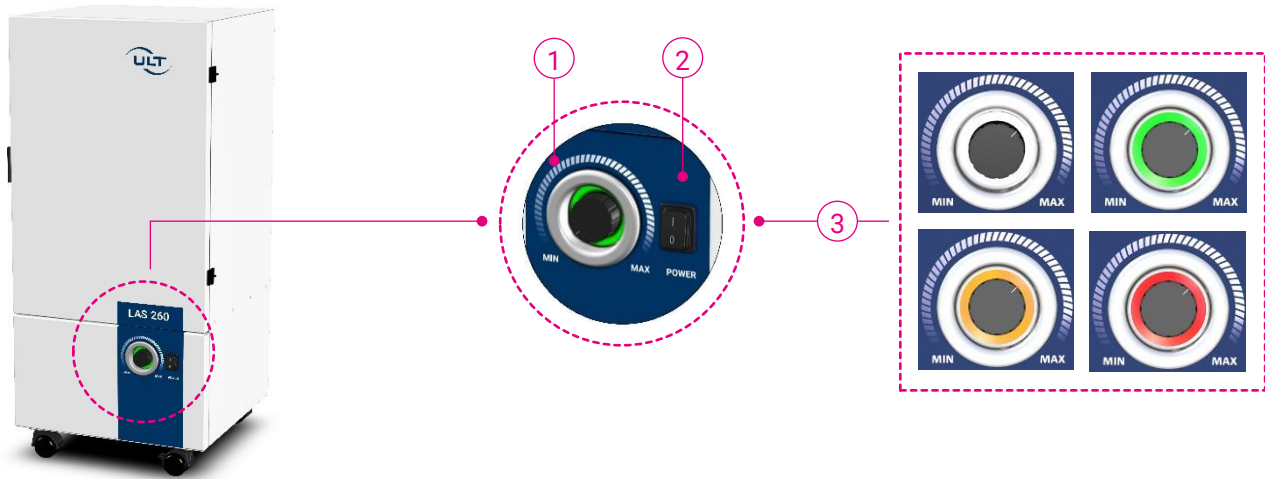

① Potentiometer

Selectable assignments:

- Direct control of the blower speed: freely set a fixed operating point within the limits of the maximum blower performance
- ecoflow CS[®]: Automatic compensation for increased filter saturation and varying numbers of collection points:
 - Control range between 120 Pa - 5,000 Pa with a suction power up to 230 m³/h

② ON/OFF switch

③ LED status ring

- Operating status indicators:
 - Standby mode via remote control (white)
 - Operation with no problems and notifications (green)
 - Warnings (orange)
 - Malfunction due to error condition (red)
- Particulate filter saturation indicator:
 - Particulate filter nearly saturated (orange)
 - Particulate filter saturated (red)



Figure 2: Interfaces on the rear

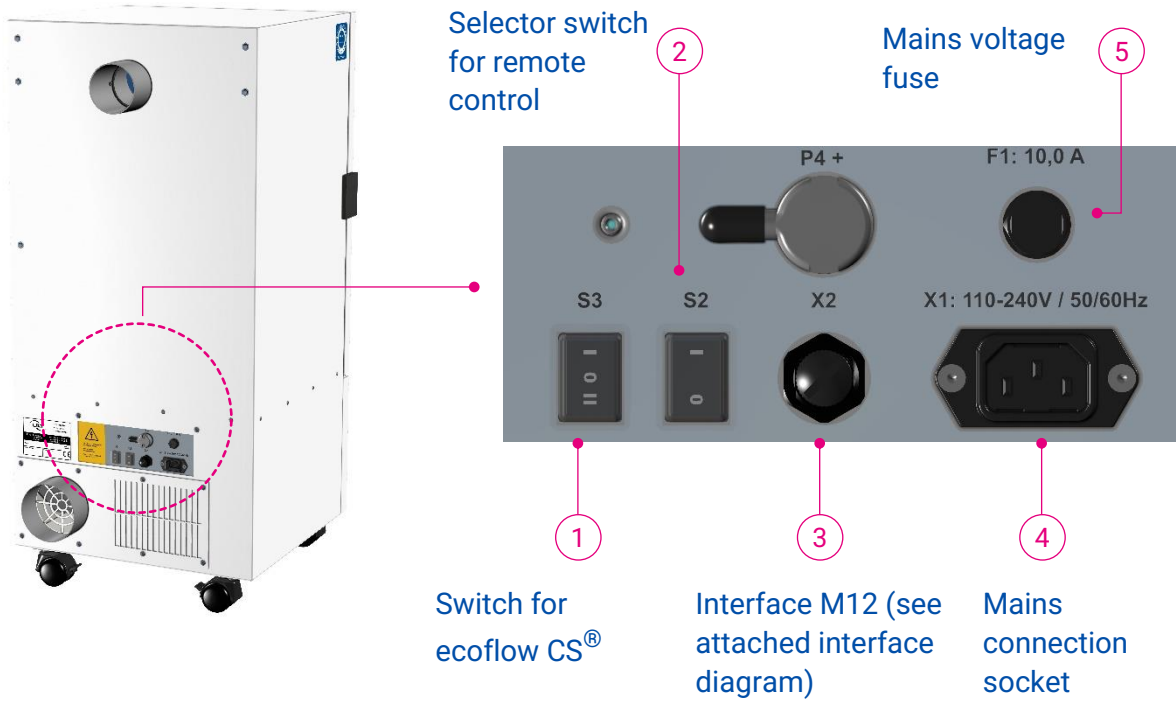



Technical Data – LAS 260.1 MD.20

Table 1: Technical Data – LAS 260.1 MD.20

PARAMETER		UNIT	
Max. volumetric flow rate	m ³ /h	360	
Max. vacuum	Pa	9,500	
Rated volumetric flow rate (fan characteristic curve)	m ³ /h @ Pa	100 @ 7,600 200 @ 5,000	
Protection class	IP	52	
Noise level (@ 50% - 100% volumetric flow rate)	dB(A)	47 - 60	
Vacuum generator type		EC blower	
Rated voltage	VAC	1~110 ... 240	
Rated frequency	Hz	50/60	
		Voltage level 120 V	Voltage level 230 V
Rated motor power	kW	0.9	0.8
Rated current	A	9.2	5.3
Energy consumption (@ 100 m ³ /h, 230 V)	W	Potentiometer setting: 	70 @ 0% 270 @ 25% 490 @ 50% 750 @ 75% 800 @ 100%
Volumetric flow rate controller		Yes	
Particulate filter saturation indicator	Visual	Yes	
Interface M12		Yes	
Dimensions (width x depth x height)	mm	440 x 508 x 958	
Weight (without filter)	kg	Approx. 29.5	
Max. weight with filter	kg	Approx. 56.5	
Air intake versions:	nozzle	1x Ø 80 mm on rear	
	Connection options	Hose connection or optional arm mounting with bracket	
Air Outlet:		Outlet grille / outlet nozzle Ø 100 mm Both included with the unit (outlet nozzle pre-assembled)	
	Position	Rear of unit at bottom	
Mains cable EU (CEE 7/7)	m	3.0 (country-specific versions can be selected)	
Options:		Spark trap Secondary filter module U15	



Characteristic Curves and Operating Modes (230 V)

Figure 3: Characteristic Curves and Operating Modes (230 V)

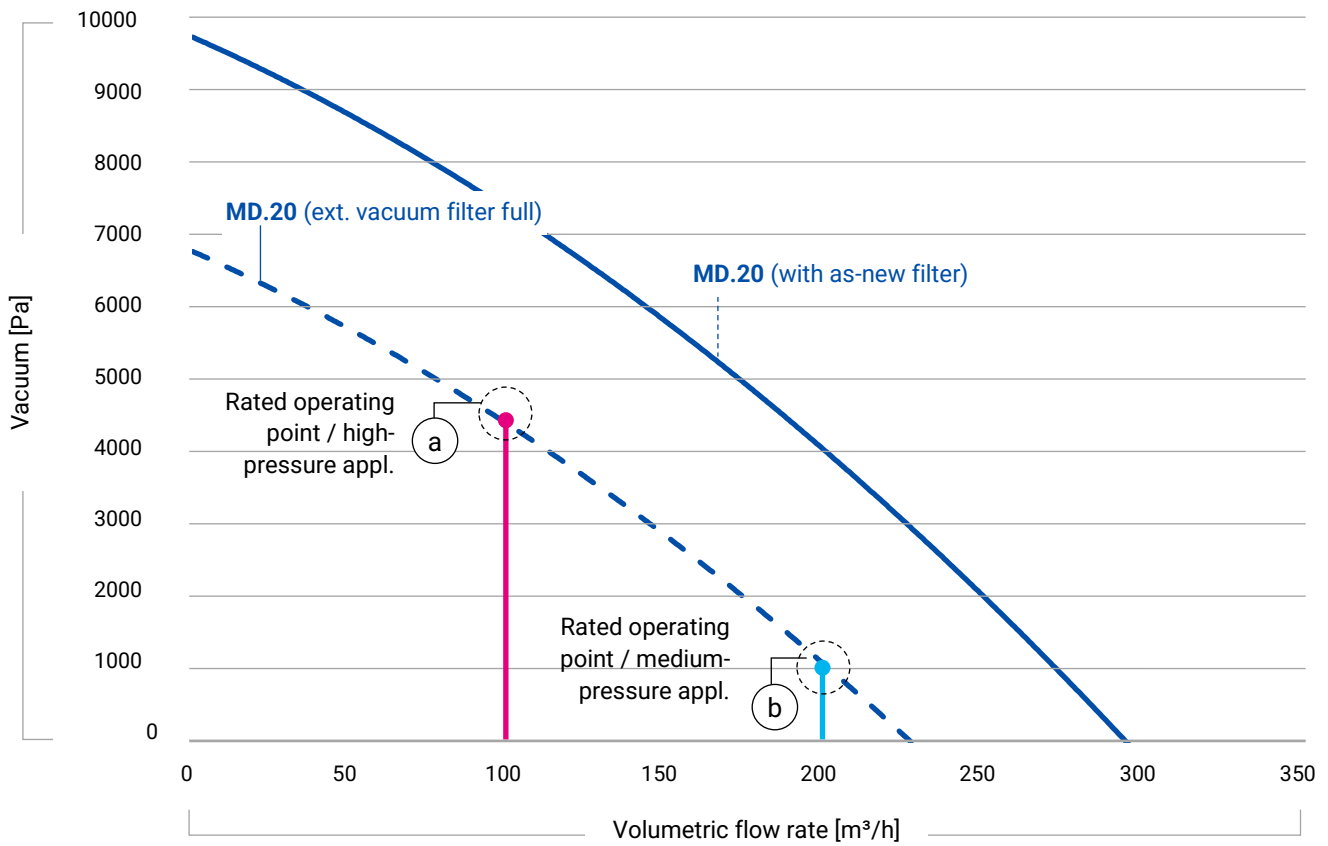



LAS Series – Laser Smoke

Areas of Application

Laser cutting | laser marking | laser structuring | laser engraving

Operating Principle

On the clean gas side of the filter, an EC blower with a high pressure reserve generates a volumetric flow rate that is matched to the target application. The volumetric flow rate can be individually regulated to a freely adjustable setting. The raw gas containing pollutants or harmful substances is thus reliably extracted.

Laser smoke is produced in a wide range of different work processes in which lasers are used. This toxic, corrosive mixture of aerosol, gas, and nanoparticles represents a health hazard and has a negative impact on the quality of products and the machining process. Depending on the particular machining process, the resulting mixtures of substances that are produced and need to be removed from the raw gas can differ greatly.

The **particles** are separated out in a multi-stage storage filtration system and retained.

Finest suspended solids are retained by the HEPA H14 filter of the combined filter cassette H14A. This guarantees a particle separation rate of 99.995%.

The separation (adsorption) of air impurities in the form of **gas or vapor** takes place in the activated carbon fill of the combined filter cassette H14A.

The filtration effect of the activated carbon is based on adsorption, i.e. the process by which (gaseous) substances adhere to the surface of the activated carbon. In general, physical adsorption does not involve any chemical changes to the substance being adsorbed. The design of the filter is based on the rated volumetric flow rate of the units, while the contact time is designed for medium adsorption behavior.

Thanks to the high degree of purification, the **filtered clean gas** can be directed back to the working space (recirculated air mode). As a result there are no thermal losses.

Recirculated air mode is not permitted when the equipment is used to extract substances that are carcinogenic, mutagenic, or toxic for reproduction, unless this is permitted by the applicable regional regulations. In these cases the outlet nozzle included with the unit should be mounted on the outlet side. The filtered clean gas must be directed via a connected pipe section into a central air outlet system.

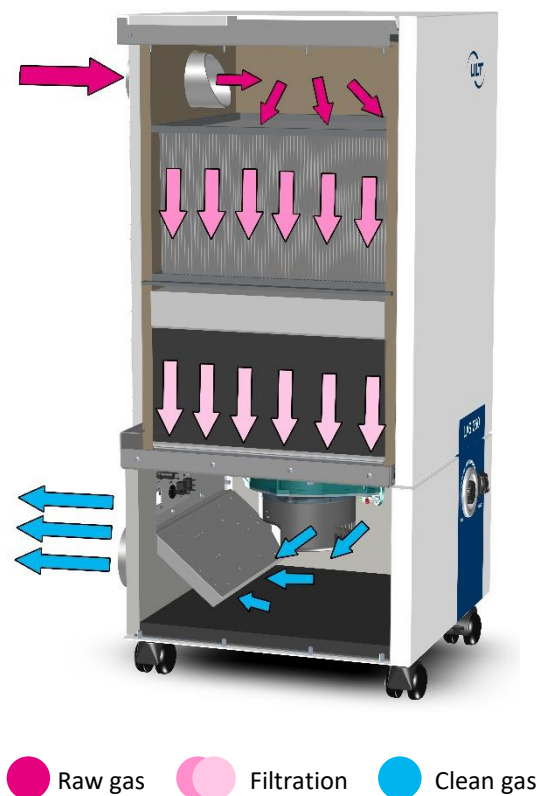



Device Variant

A reliable filter combination is available for the extraction and filtration of harmful gas/dust mixtures from laser machining processes. For competent advice and help choosing the right filter combination, please contact your local dealer or get in touch with ULT AG directly via ult@ult.de.

The units in the LAS 260.1 series are equipped with the following filter configuration based on the individual requirements:

LAS 260.1 MD.20 FK

A pre-filter cassette retains particles and prevents premature saturation of the downstream H14 main filter element. This multi-stage filter configuration is particularly well suited to the separation of dry laser smoke.

Table 2: LAS 260.1 MD.20 FK

Part number for complete device:		1-00192
Filter configuration for laser smoke:		
Pre-filter cassette		
(1)	Raw gas intake	
(2)	Particulate filter F, fine dust filter	
	Filter class:	ISO ePM ₁ 80% in acc. with ISO 16890
Combined filter cassette H14A		
(3)	Particulate filter H14	
	Filter class:	H14 HEPA filter, particulate air filter in acc. with EN 1822
(4)	Adsorption filter A10	
	Filter medium:	Activated carbon fill, 10 kg

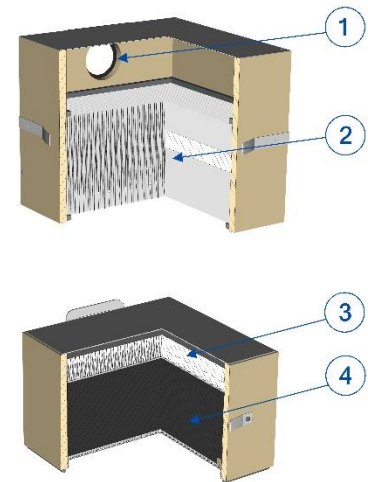



Accessory items

DN50 extraction system

Hoses



Flexible extraction hose DN 50, 2m	Antistatic, incl. 90° bend, socket and worm drive hose clips	3-00485
Flexible extraction hose DN 50, 3m	Antistatic, incl. 90° bend, socket and worm drive hose clips	3-00486
Flexible extraction hose DN 50, 5m	Antistatic, incl. 90° bend, socket and worm drive hose clips	3-00487
Flexible extraction hose DN 50, per meter	Antistatic, without accessories	6-06872

Hose accessories



Reducer DN 80 – DN 50	for device nozzle DN80	3-01294
Reducer DN 80 – 2x DN 50	Incl. 90° bend and socket	3-01319
Bend 90° DN 50	Antistatic, incl. worm drive hose clamp	3-00494
Socket DN 50	Antistatic, incl. worm drive hose clamp	3-00495
Y-piece DN 50 - 2*DN 50	Antistatic	6-06970

Extraction arm mounting elements



Table bracket black	Alsident System 50, accessory	2-5010-050
Device mounting console 2 x S50 extraction arm	incl. mounting material and connector hose	3-01283

Extraction arms



Alsident system 50, antistatic extraction arm	945 mm for table/device mounting	50-4737-1-6
---	----------------------------------	-------------

Collecting elements



Flat screen antistatic	Alsident System 50, accessory	1-503324-6
Round hood aluminium antistatic	Alsident System 50, accessory	1-5024-6
Extractor tube antistatic	Alsident System 50, accessory	1-5021-6
Suction gap antistatic	Alsident System 50, accessory	1-5020-6



DN80 extraction system

Hoses



Flexible extraction hose DN 80, 2m	Antistatic, incl. 90° bend, socket and worm drive hose clips	3-00489
Flexible extraction hose DN 80, 3m	Antistatic, incl. 90° bend, socket and worm drive hose clips	3-00490
Flexible extraction hose DN 80, 5m	Antistatic, incl. 90° bend, socket and worm drive hose clips	3-00491
Flexible extraction hose DN 80, per meter	Antistatic, without accessories	6-06874

Hose accessories



Bend 90° DN 80	Antistatic, incl. worm drive hose clip	3-00496
Socket DN 80	Antistatic, incl. worm drive hose clip	3-00497
Reducer DN 80 - DN 75	Antistatic, for connecting a DN80 hose to the System 75 extraction arm, incl. worm drive hose clip	3-00499

Extraction arm mounting elements

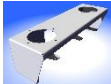

Table bracket white	Alsident System 75, accessory	2-7510
Device mounting console 1x S75 extraction arm	incl. mounting material and connector hose	3-01280

Extraction arms



Alsident System 75, extraction arm	1290mm for table/device mounting	75-6555-1-5
------------------------------------	----------------------------------	-------------

Collecting elements



Flat screen	Alsident System 75, accessory	1-753324-5
Round hood aluminium	Alsident System 75, accessory	1-7524-5
Extractor tube	Alsident System 75, accessory	1-7525



DN100 exhaust air system

Hoses and hose accessories



Flexible extraction hose DN 100, per meter	Antistatic, without accessories	6-06875
Socket DN 100	Antistatic, incl. worm drive hose clip	3-00500

Interface accessories

M12 interface accessories



M12 connection cable	incl. M12 Male adapter, length 3m	3-00234
M12 On/Off foot switch	incl. M12 Male adapter, length 3m	3-00235

Device power cables – supplied free of charge with ordered device



Swiss device power cable	Length 3.00 m	6-06056
UK device power cable	Length 2.00 m	6-06063
USA device power cable	Length 2.00 m	6-06091
EU device power cable (CEE 7/7)	Length 3.00 m	6-05990

Spark pre-separator



Spark pre-separator NT092	For device mounting, incl. mounting material and connector hose	3-01281
---------------------------	---	---------

Secondary filter U15

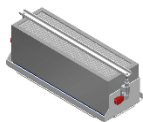

LAS 260.1 secondary filter module U15	Retrofit kit for exhaust air filtration	3-01277
Particle filter U15	For secondary filter	6-11662



Replacement filter

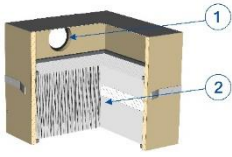

Particle filter cassette F9

4-00107

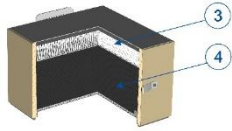

Combined filter cassette H14A

4-00109

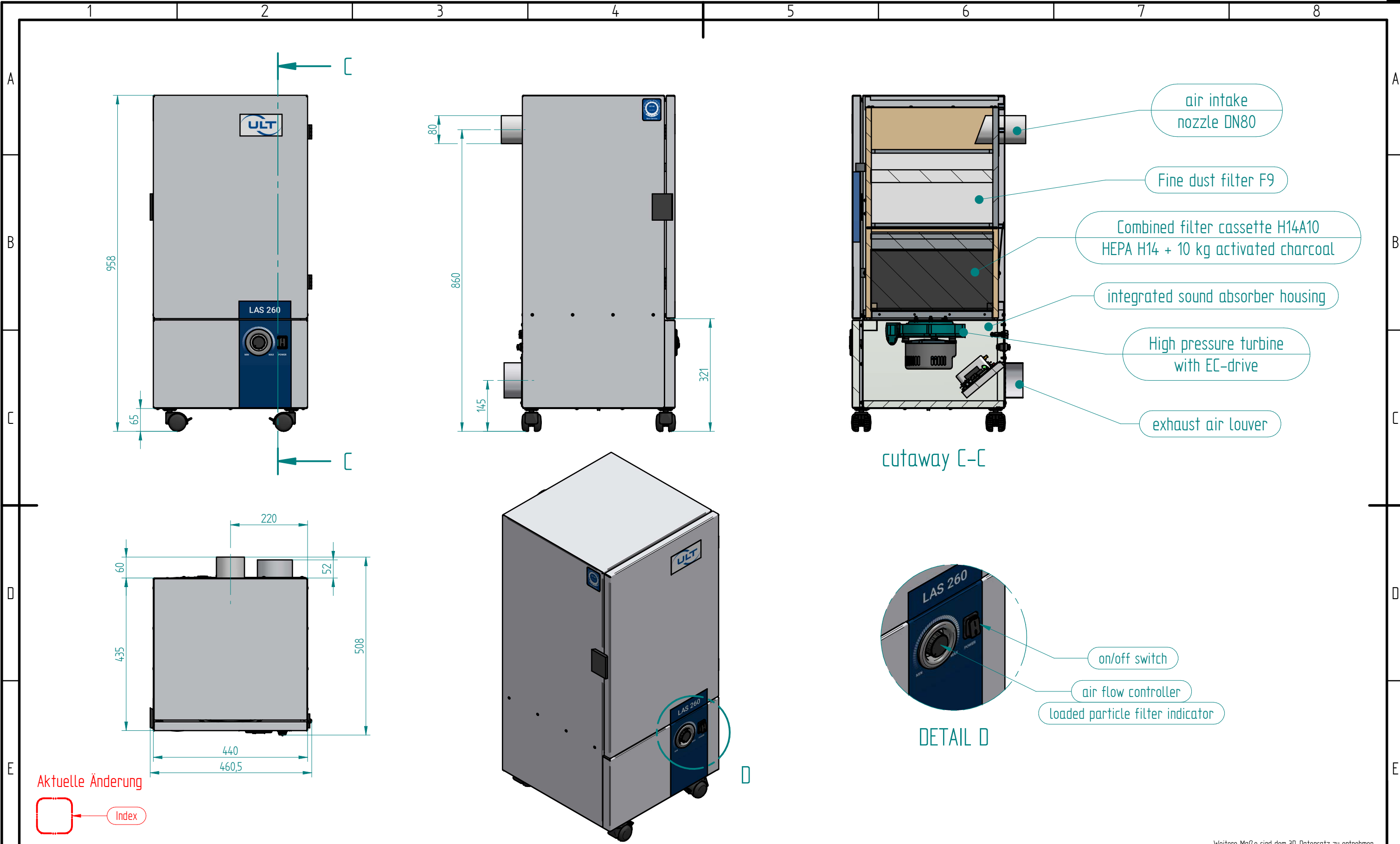

Revisionen					Abteilung	Technische Referenz	Dokumentenstatus	Erstellt von	Erstellt am	
Index	Beschreibung	Blatt	Datum	Bearbeiter	Konstruktion		Verfügbar	t.graczyk	26.10.2022	
000	Basis						Titel / Untertitel	Gepüft von	Gepüft am	
							LAS 260.1			
					ULT AG Am Göpelteich 1 D-02708 Löbau Schutzvermerk ISO 16016 beachten.		Dokumentnummer	Dokumententyp		
							LAS260.1_00_001	Revision	Sprache	Maßstab
							000	DE	1:1	2 von 2

Weitere Maße sind dem 3D-Datensatz zu entnehmen.

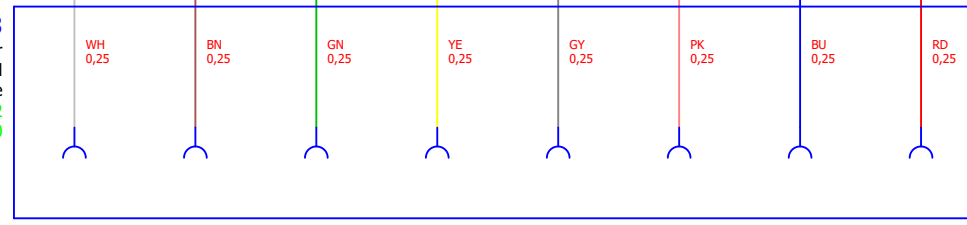
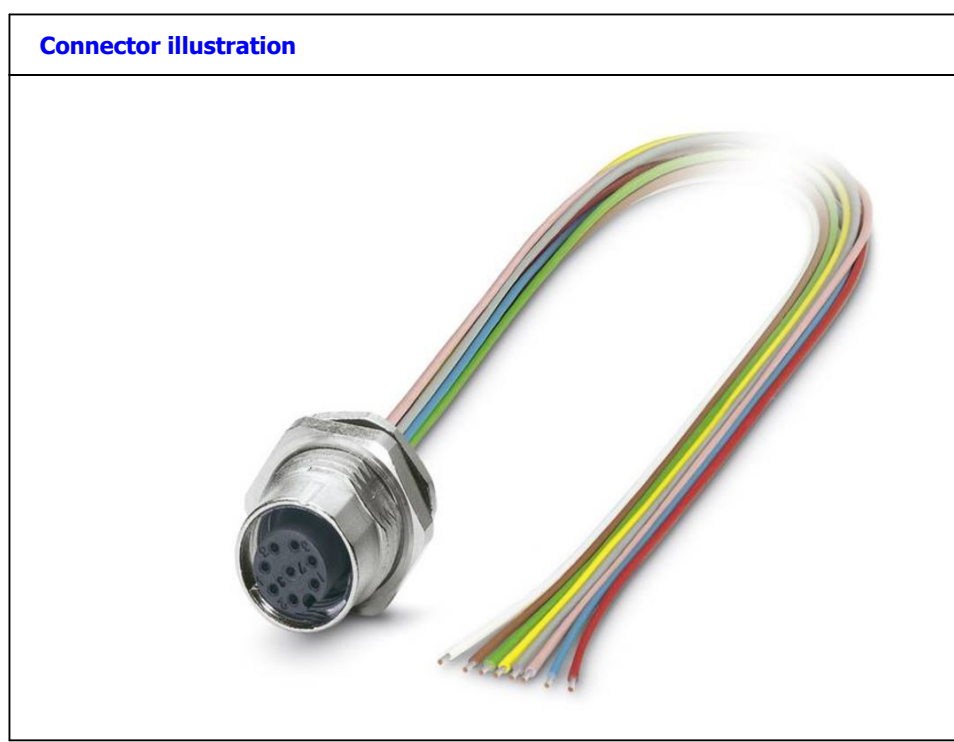
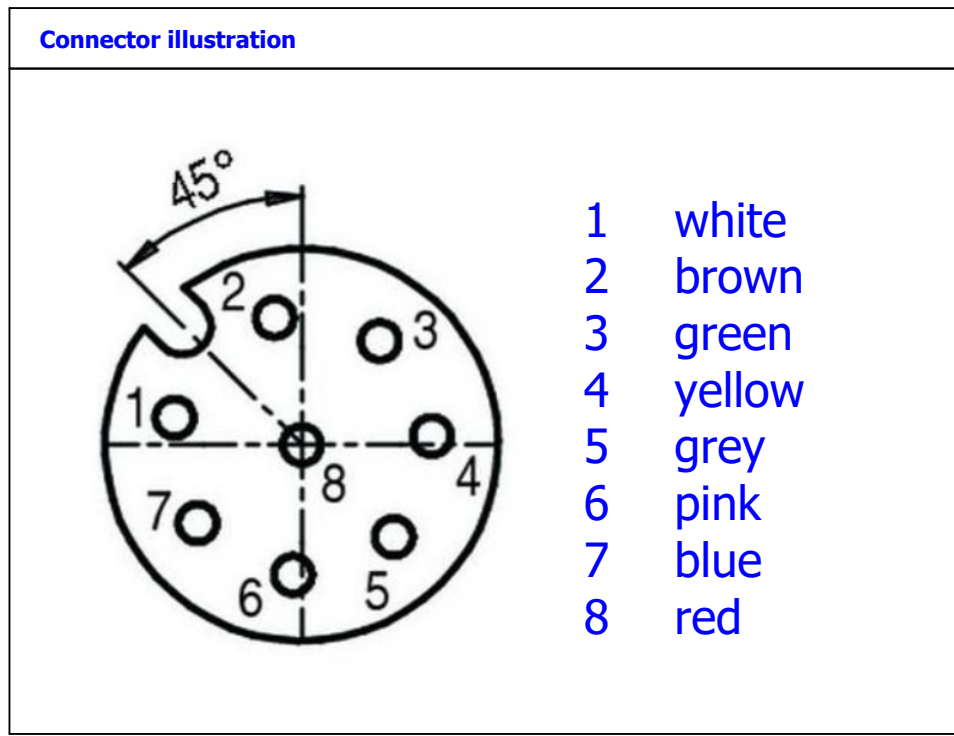
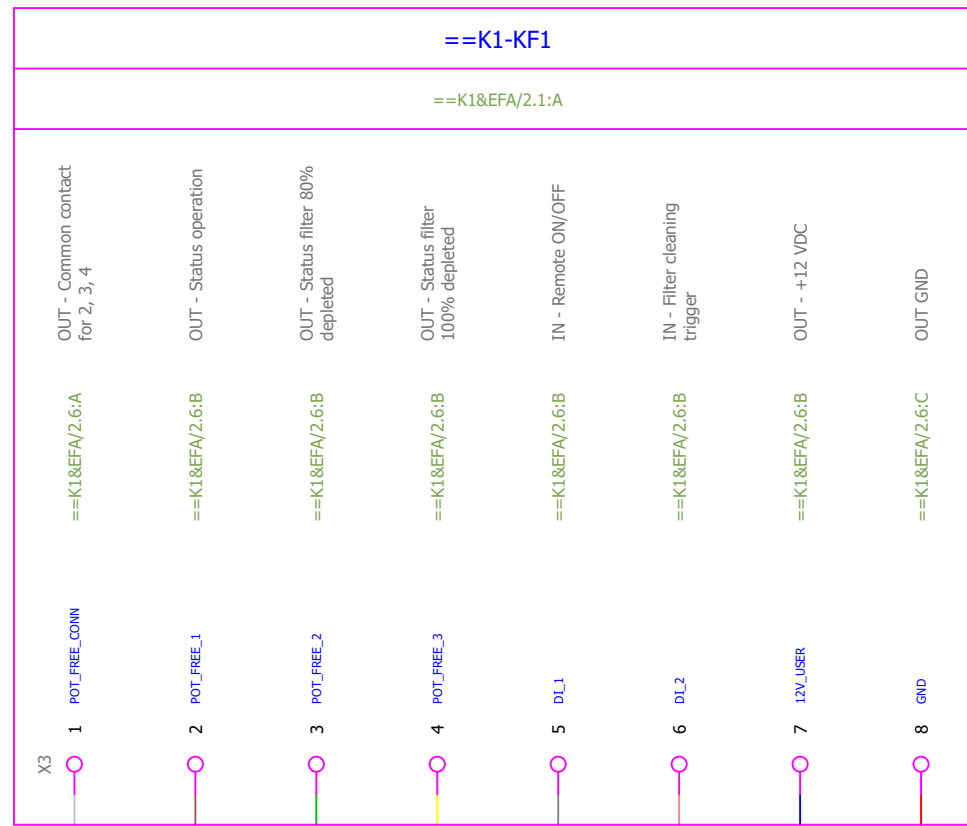

-XG13
 I/O Connector
 Cap IP67 included
 DIN EN 61076-2-101 / M12 / A-coded / 8-pin / Female
 6-05462
 6-09330

ULT AG Am Göpelteich 1, 02708 Löbau Phone: +49 (0) 3585-4128-0 Mail: ult@ult.de Copyright according to ISO 16016.	Document Title LAS 260.1 MD.20	Department Design	Technical reference R.Schütze	Created by R.Schütze	Created on 17.01.2023	Document status Available	Document type ePlan	
		Page description Interface I/O		Checked by	Checked on	Document identifier / page number ==X1+CE1&EFS/2		
		Document number LAS 260.1_60_000		Approved by	Approved on	Revision 000	Page 22	Pages 24

Design A: Internal power supply

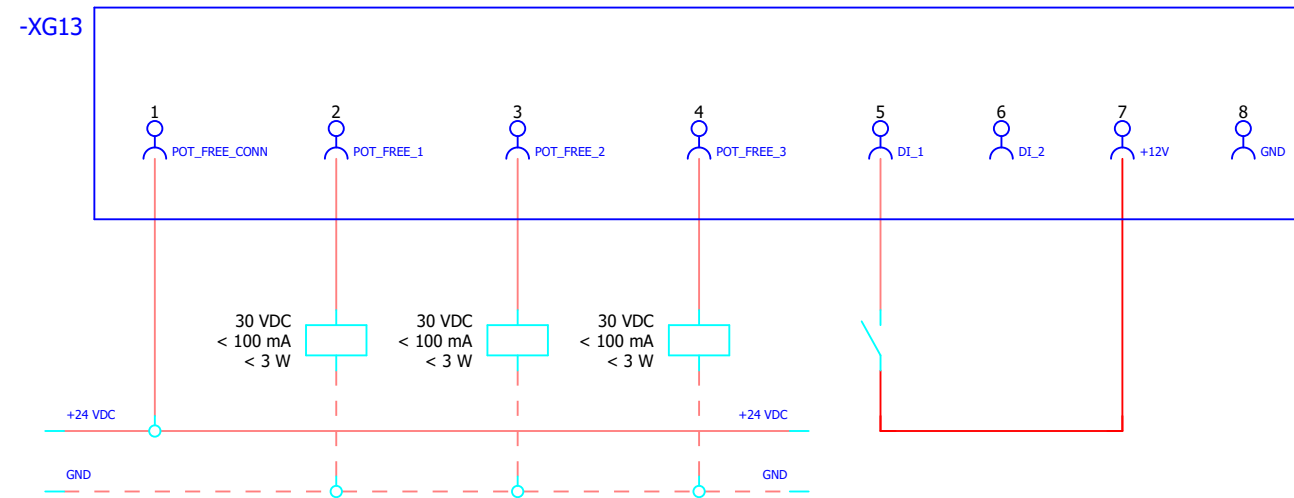

XG13 DIN EN 61076-2-101 / M12 / A-coded / 8-pin / Female

PIN	Function	Potential	Rating	Status	Description
1-2	Status operation (1)	Potential free	< 30 VDC < 100 mA	Open	Machine out of operating
				Closed	Machine operating
1-3	Status filter (1)	Potential free	< 30 VDC < 100 mA	Open	Filter 80% depleted
				Closed	Filter OK
1-4	Status filter (1)	Potential free	< 30 VDC < 100 mA	Open	Filter 100% depleted
				Closed	Filter OK
5-7	Remote ON/OFF (2)	24 VDC	24 VDC	High	Maschine ON
				Low	Maschine OFF

Note (1): Signals are only to be evaluated when the unit is connected to supply voltage and the main switch is ON.

Note (2): Control with internal power supply (pin 7) or with external customer power supply (max. 24 VDC). The GND from the external power supply must be connected to the GND from the machine (pin 8).

Design B: External customer power supply

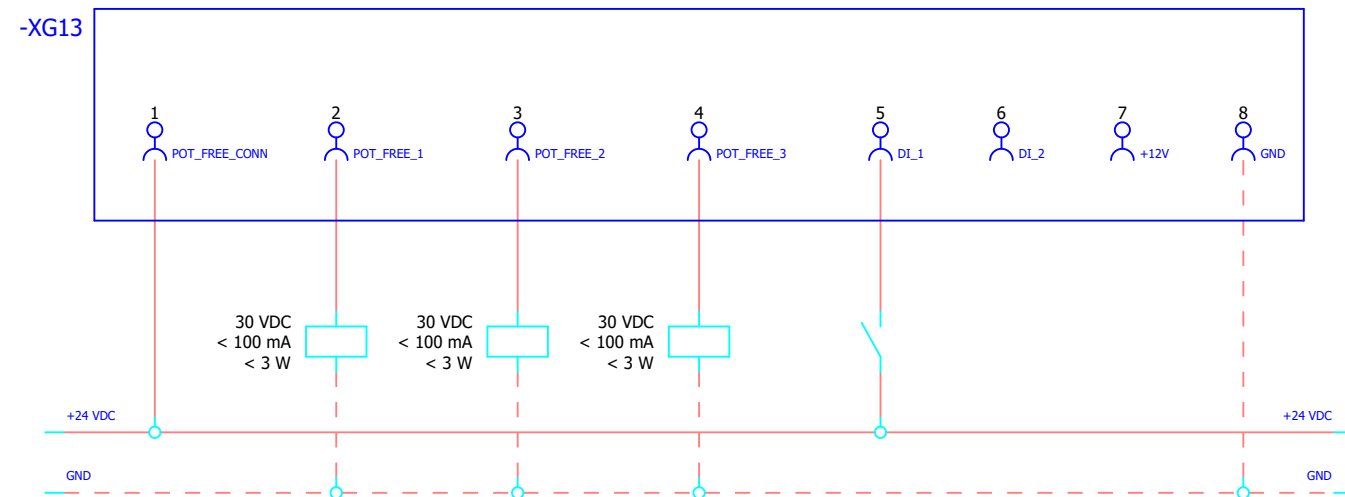

==+&EPC/1

ULT AG

Am Göpelteich 1
02708 Löbau
Germany

Phone: +49 3585 4128-0
Fax: +49 3585 4128-11
E-mail: ult@ult.de
Website: www.ult.de



air quality