



Technical Documentation

ULT 200.1

Version 014



Contents

Description of Product Series	4
Features of the ULT 200.1 extraction and filtration unit	4
Equipment	5
Technical Data ULT 200.1 MD.20	7
Characteristic Curves and Operating Modes (230 V)	8
Application ACD – Odor, Gas and Vapors	9
Areas of application	9
Functional principle	9
Device variants	10
ACD 200.1 MD.20 A6	10
ACD 200.1 MD.20 A14	11
Application ASD – dust and smoke	12
Areas of application	12
Functional principle	12
Device variants	13
ASD 200.1 MD.20 H	13
ASD 200.1 MD.20 TH	14
Application LAS – laser smoke	15
Areas of application	15
Functional principle	15
Device variants	16
LAS 200.1 MD.20 K	16
LAS 200.1 MD.20 TK	17
Application LRA – Soldering smoke	18
Areas of application	18
Functional principle	18
Device variants	19
LRA 200.1 MD.20 K	19
Accessory items	20
DN50 extraction system	20
DN80 extraction system	21
DN100 exhaust air extraction system	22
Interface accessories	22
Secondary filter U15	22
Replacement filter	23



Annexes:

- Drawing, device size M
- Drawing, device size L
- M12 plan of interfaces



Description of Product Series

The **ULT 200.1 product range** is suited to collecting and filtering contaminants and impurities in the form of dusts and gases. There are suitable multi-level filtering systems **for every possible industrial** application and the most diverse compositions of harmful or unwanted substances.

The contaminants and impurities generated during the customer's process are collected directly from the point of origin via the collection elements and filtered by the ULT 200.1 devices. **High precipitation rates** are achieved thanks to the targeted combination of the available single filters. The underlying filter technology uses the principles of particle separation for dust and the principles of adsorption and chemisorption for gaseous substances.

Features of the ULT 200.1 extraction and filtration unit

- with an **exchangeable filter system** – low-contamination removal
- **low replacement filter costs** thanks to the multi-level filter system with competitively priced prefilter elements with increased absorption capabilities
- suitable **for a broad range of applications**: Use of a blower compatible with large negative pressures and large volumetric flows
- **very low energy consumption** thanks to energy-efficient electronics
- **global use** possible thanks to electrical equipment supplied: operates at 110 – 240 V
- all electrical components in versions compliant with both UL and CE
- integrated sound insulation ensures that the device operates **extremely quietly**
- rugged sheet steel housing with RAL7035 light gray **powder coating**
- **mobile device** with castors
- all interfaces on the back
- operating and display elements on the front

Thanks to the high degree of cleaning, the filtered clean gas can then be returned to the working area (**recirculated-air** operation). This avoids any loss of heat. If recirculated-air operation is not wanted, outgoing air operation can be implemented by simply assembling a pipe spigot which is included in the scope of delivery for the device. The filtered clean gas can then flow into an exhaust **air extraction** system.

The ULT 200.1 devices can be perfectly combined with a **diverse range of accessories**. The right accessories can be selected according to the customer requirements.





Equipment

Figure 1: Front operating panel

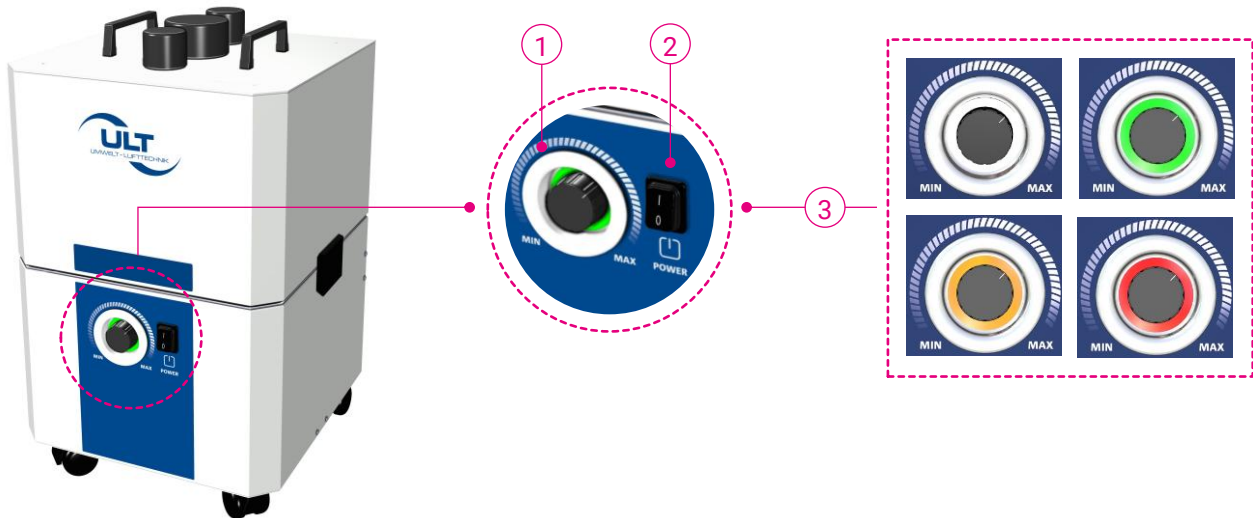

① Potentiometer

Selectable assignments:

- Direct control of the blower speed: Random working point can be permanently set within the limits of the maximum blower output
- Negative pressure stabilization: automatic compensation of increasing filter clogging and changing number of extraction points, two modes selectable:
 - Medium-pressure mode: control range between 150 and 1,000 Pa
 - High-pressure mode: Control range between 150 and 5,000 Pa

② On/Off switch

③ LED status ring

Machine status display:

- Standby operation via remote control (white)
- Malfunction-free operation (green)
- Malfunction caused by fault condition (flashing orange/red)
- Loaded particle filter indicator:
 - Particulate filter almost saturated (orange)
 - Particulate filter saturated (red)



Figure 2: Interfaces on the rear

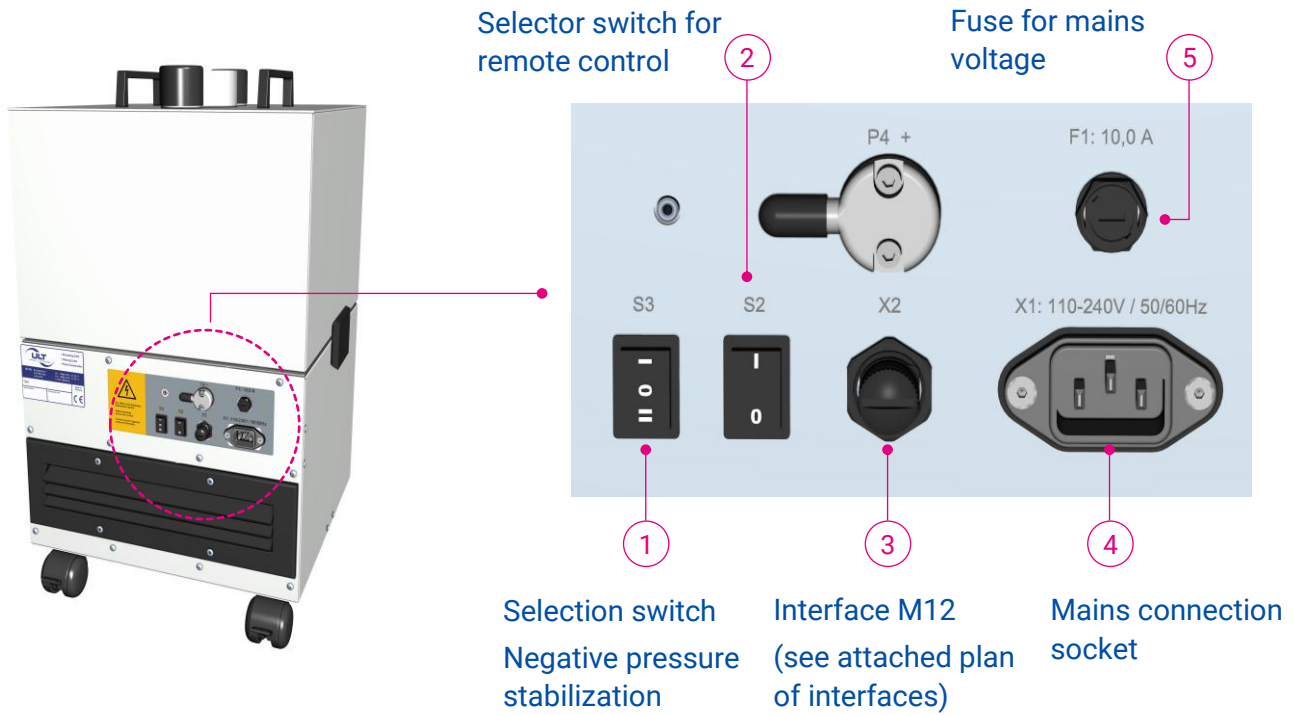



Technical Data ULT 200.1 MD.20

Table 1: Technical Data ULT 200.1 MD.20

PARAMETER	UNIT		
Max. volumetric flow rate	m ³ / h	320	
Max. vacuum	Pa	9.000	
Rated volumetric flow rate (fan characteristic curve)	m ³ /h @ Pa	130 @ 5.000 230 @ 1.000	(a: High-pressure application) (b: Medium-pressure application)
Protection class	IP	54	
Noise level (@ 50% - 100% volumetric flow rate)	dB(A)	47 - 58	
Vacuum generator type			EC-blower
Rated voltage	VAC	1~110 ... 240	
Rated frequency	Hz	50/60	
		Voltage level 120 V	Voltage level 230 V
Rated motor power	kW	0,75	0,75
Rated current	A	9,2	5,3
Volumetric flow rate controller			yes
Particulate filter saturation indicator	Visual		yes
Interface M12			yes
		Configuration M	Configuration L
Dimensions (width x depth x height)	mm	390 x 400 x 620	390 x 400 x 775
Weight (without filter)	kg	approx. 21	approx. 23
Max. filter weight	kg	approx. 15	approx. 25
Air intake versions:	nozzle	1 x Ø 80 mm and 2 x Ø 50 mm available on the roof	
Connection options		Hose connection or optional arm assembly with console	
Air outlet:		Adjustable exhaust grille / exhaust nozzle Ø 100 mm, both included in scope of delivery for device	
	position	Device rear, bottom	
Mains power cable EU (CEE 7/7)	m	3,0 (country-specific versions selectable)	



Characteristic Curves and Operating Modes (230 V)

Figure 3: Characteristic Curves and Operating Modes (230 V)

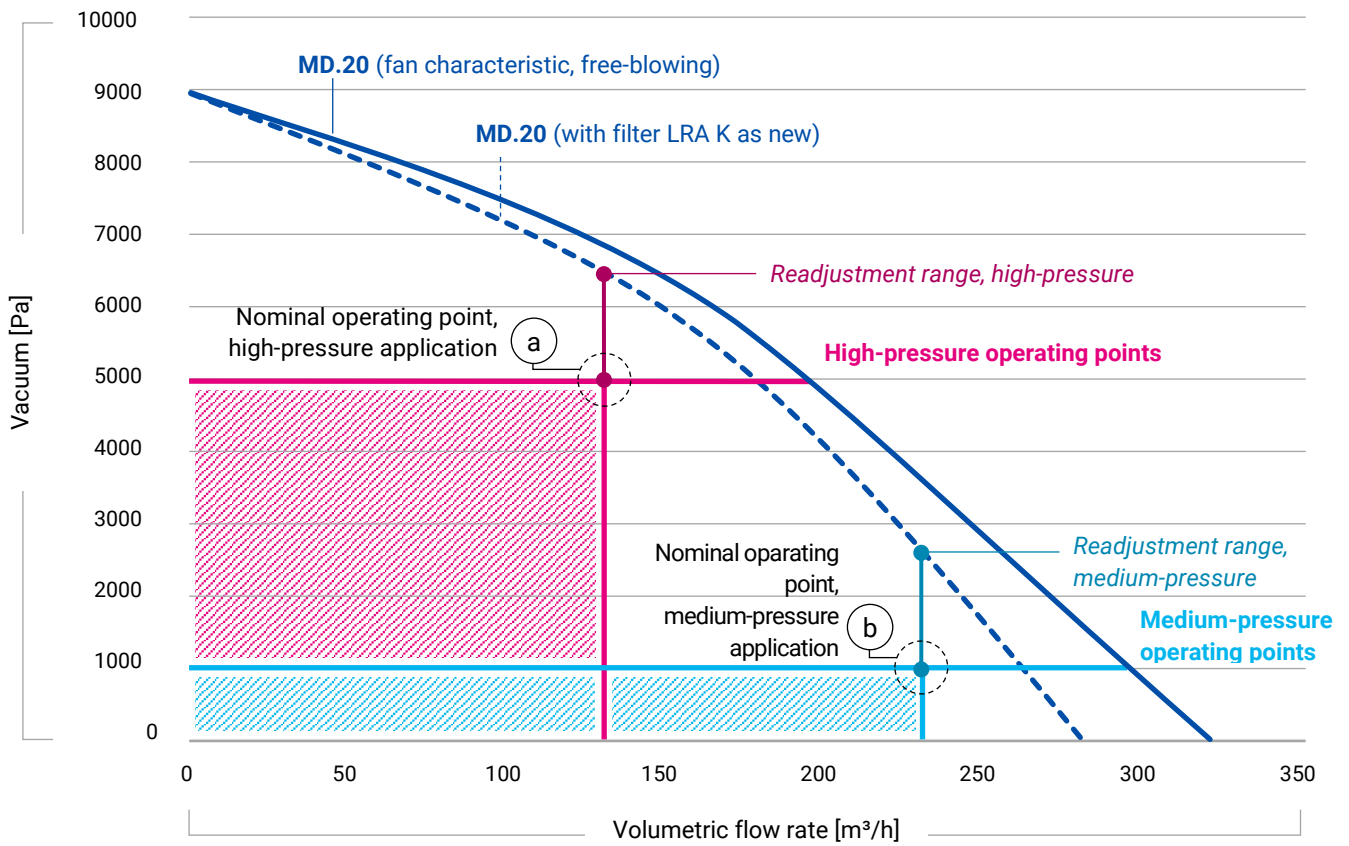

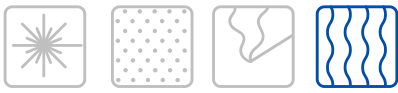

Application ACD – Odor, Gas and Vapors

Areas of application

Adhesive Bonding | Pre-treating | Varnishing/Printing | Cleaning | Laminating | Casting

Functional principle

An EC blower with a high pressure reserve generates a volumetric flow suitable for the application on the cleangas side of the filter. The volumetric flow can be controlled individually and steplessly. In this way, the pollutant-laden **raw gas** is extracted in a reliable manner.

The **coarse-dust particles** are precipitated and held back in the first filter stage. The precipitation (adsorption) of **gaseous and vaporous** air contaminations takes place in the activated carbon filter.

The filter effect of the activated carbon is based on **adsorption**, i.e. on the depositing of (gaseous) substances on the surface of the activated carbon. In general, no chemical changes of the adsorbed substance take place in physical adsorption. The filter construction is adapted to the nominal volumetric flow of the devices so that the contact period is sufficient for achieving a good adsorption response. Activated carbon is not suitable as an adsorption medium in the presence of a multitude of gases and gaseous mixtures. The **chemisorption** adsorption process can be used in such applications, either as an alternative or as a supplement. A chemical alteration of the substances to be precipitated takes place in this connection.

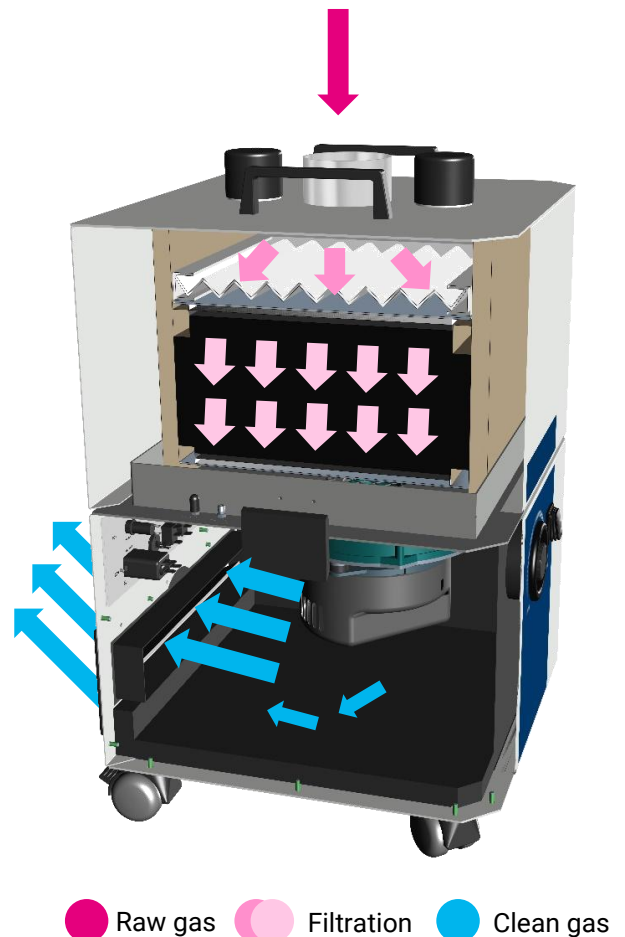

When this procedure is used, the filter is filled with a mixture of activated carbon and chemisorption medium or the activated carbon is replaced in its entirety by the chemisorption medium.

Thanks to the high degree of cleaning, the **filtered clean gas** can then be returned to the working area (**recirculated-air** operation). This avoids any loss of heat.

Recirculated air operation is not permitted for the suctioning and filtration of carcinogenic, mutagenic or reprotoxic substances. The **exhaust air spigot** that is included in the scope of delivery for the device is to be mounted on the blow-out side in such cases. The filtered clean gas must be channeled through a connected pipeline into a central discharge air system.



Device variants

A variety of filter combinations is available for the suctioning and filtration of gases, odors and vapors. The available filter materials exhibit different suitabilities for precipitation, depending on the contaminant present. For expert advice for the selection of the correct filter medium, please contact your local dealer or ULT AG directly using ult@ult.de.

In accordance with customer-specific requirement, the ULT 200.1 devices can be equipped with the following filter set-ups:

ACD 200.1 MD.20 A6

Table 2: ACD 200.1 MD.20 A6

Part number for complete device:	1-00004
Filter for organic gases:	Main filter module A6
(1) Z-Line filter G4	
Filter class:	ISO Coarse 90% according to ISO 16890
(2) Adsorption filter cassette A6	
Filter medium:	Activated carbon bed (6 kg)

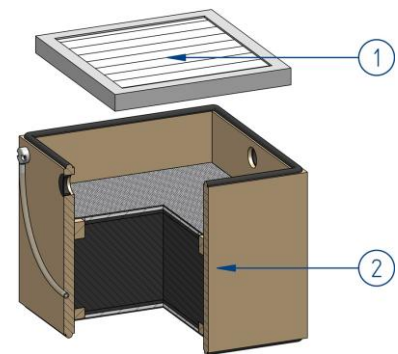
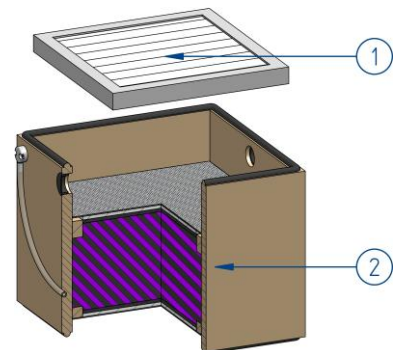
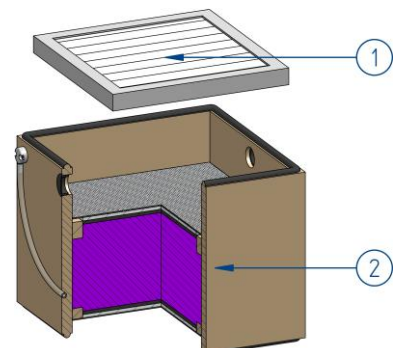

Table 3: ACD 200.1 MD.20 A6 (optional filter set-up)

Part number of option:	9-00048
Filter for gas mixtures:	Main filter module AC7
(1) Z-Line filter G4	
Filter class:	ISO Coarse 90% according to ISO 16890
(2) Chemisorption filter cassette AC7	
Filter medium:	Granulate bed made of 50% activated carbon and 50% chemisorption medium (total 7 kg)



Part number of option:	9-00049
Filter for gaseous sulfur & nitrogen compounds:	Main filter module C11
(1) Z-Line filter G4	
Filter class:	ISO Coarse 90% according to ISO 16890
(2) Chemisorption filter cassette C11	
Filter medium:	Granulate bed made of 100% chemisorption medium (11 kg)



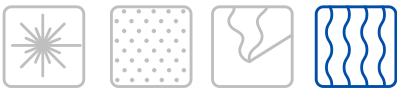

ACD 200.1 MD.20 A14

Table 4: ACD 200.1 MD.20 A14

Part number for complete device:	1-00005
Filter for organic gases:	Main filter module A14
(1) Z-Line filter G4	
Filter class:	ISO Coarse 90% according to ISO 16890
(2) Adsorption filter cassette A14	
Filter medium:	Activated carbon bed (14 kg)

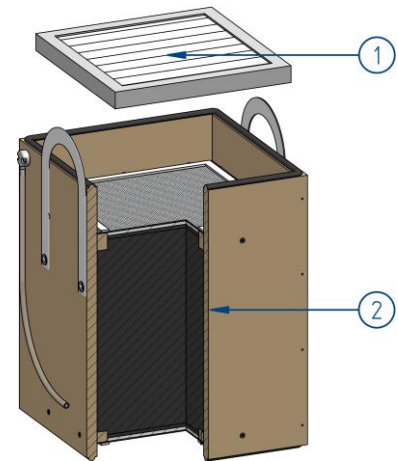
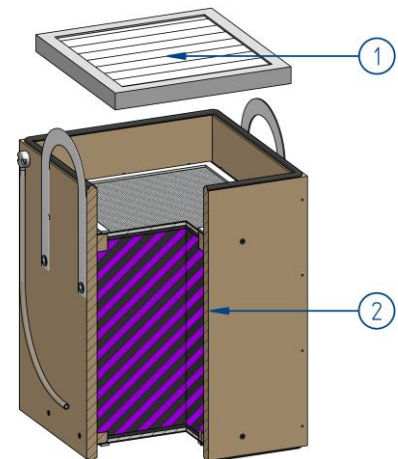
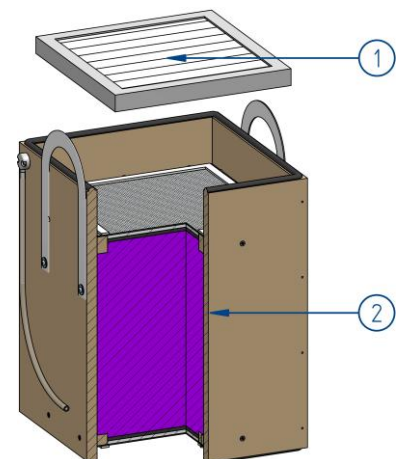

Table 5: Optional filter set-up

Part number of option:	9-00050
Filter for gas mixtures:	Main filter module AC17
(1) Z-Line filter G4	
Filter class:	ISO Coarse 90% according to ISO 16890
(2) Chemisorption filter cassette AC17	
Filter medium:	Granulate bed made of 50% activated carbon and 50% chemisorption medium (total 17 kg)



Part number of option:	9-00051
Filter for gaseous sulfur & nitrogen compounds:	Main filter module C20
(1) Z-Line filter G4	
Filter class:	ISO Coarse 90% according to ISO 16890
(2) Chemisorption filter cassette C20	
Filter medium:	Granulate bed made of 100% chemisorption medium (20 kg)





Application ASD – dust and smoke

Areas of application

Grinding | Engraving | Polishing | Filling and dosing processes | Restoration work

Functional principle

An EC blower with a high pressure reserve generates a volumetric flow suitable for the application on the cleangas side of the filter. The volumetric flow can be controlled individually and steplessly. In this way, the pollutant-laden raw gas is extracted in a reliable manner.

In production processes in which **powder materials** are processed or materials are sawed, milled or ground, dust contaminates the working area. In addition, **mechanical processes** can generate smoke by heating the processed materials. **Dust and smoke** are harmful to health and affect the quality of production processes. For this reason, these pollutants must be removed from the work area.

The application ASD provides **two filter solutions** for this with different filter elements for precipitating the **particles** that accumulate. Regularly changing the prefilter elements at shorter intervals prevents any premature clogging of the downstream H14 main filter element and significantly extends the functionality of the main filter.

Extremely fine suspended matter is retained by the High Efficiency Particulate Air filter H14 filter of the particulate filter cassette H14. This guarantees a **precipitation rate of 99.995%**.

Thanks to the high degree of cleaning, the **filtered clean** gas can then be fed back into the working area (**recirculated-air** operation). This avoids any loss of heat.

Recirculated air operation is not permitted for the suctioning and filtration of carcinogenic, mutagenic or reprotoxic substances. The **exhaust air** spigot that is included in the scope of delivery for the device is to be mounted on the blow-out side in such cases. The filtered clean gas must be channeled through a connected pipeline into a central discharge air system.

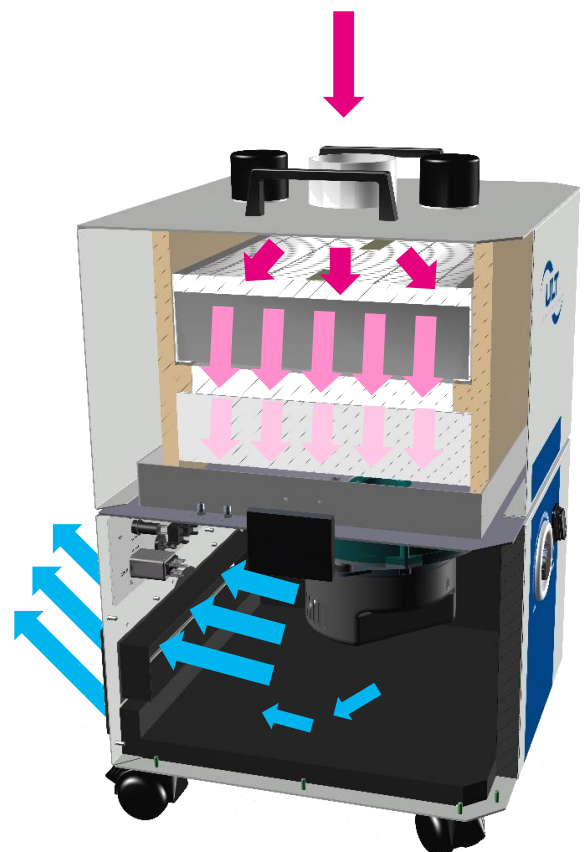

● Raw gas ● Filtration ● Clean gas



Device variants

A wide range of different filter combinations is available for the extraction and filtration of air pollutants in the form of dust and smoke. The precipitation effectiveness of the available filter combinations depends on the machining process used. For expert advice when choosing the correct filter combination, please contact your local dealer or ULT AG directly using ult@ult.de.

In accordance with customer-specific requirement, the series ULT 200.1 devices can be equipped with the following filter attachments:

ASD 200.1 MD.20 H

An upstream panel filter F retains most of the particles that accumulate. Due to its special folding, a large volume is provided for absorbing coarse dust. At the same time, **a large filter surface** enables the precipitation of the finest dusts even at high raw gas flow rates.

Table 6: ASD 200.1 MD.20 H

Part number of complete device:	1-00025
Part number of complete device:	Main filter module H
(1) Panel filter F, fine dust filter	
Filter class:	ISO ePM2,5 75% according ISO 16890
(2) Particle filter cassette H14 with filter mat	
(2.1) Filter mat G, filter protection	
Filter class:	ISO Coarse 85% acc. to ISO 16890
(2.2) Particulate filter H14	
Filter class:	H14 HEPA-filter, suspended matter filter to DIN EN 1822

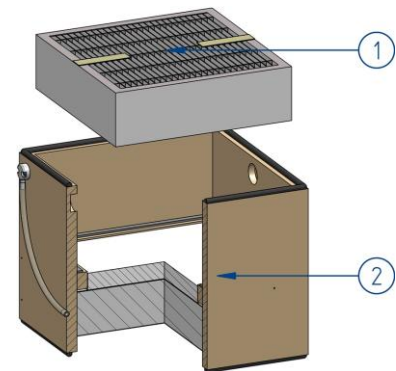



ASD 200.1 MD.20 TH

As an alternative, a device version is available in which a pocket filter is used for pre-precipitation. It is particularly suitable for processes in which large amounts of dust and lint accumulate. The pocket filter provides **a very large storage volume** and is therefore also suitable for extracting coarse, nondusty processing residues.

Table 7: ASD 200.1 MD.20 TH

Part number of complete device:	1-00026
Filter set-up for dust and smoke:	Main filter module TH
(1) Pocket filter F, fine dust filter	
Filter class:	ISO ePM1 80% according to ISO 16890
(2) Empty frame for pocket filter	
(3) Particle filter cassette H14 with filter mat	
(3.1) Filter mat G, filter protection	
Filter class:	ISO Coarse 85% acc. to ISO 16890
(3.2) Particulate filter H14	
Filter class:	H14 HEPA filter, suspended matter filter to DIN EN 1822

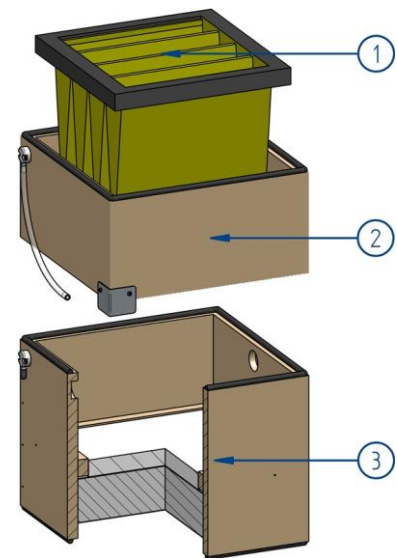



Application LAS – laser smoke

Areas of application

Laser Cutting | Laser Marking | Laser Structuring | Laser Engraving

Functional principle

An EC blower with a high pressure reserve generates a volumetric flow suitable for the application on the cleangas side of the filter. The volumetric flow can be controlled individually and steplessly. In this way, the pollutant-laden raw gas is extracted in a reliable manner.

The versatile work processes in which lasers are used generate **laser smoke**. This toxic, corrosive mixture of aerosol, gas and nanoparticles poses a health hazard and adversely affects the product and process quality. Depending on the process, very different precipitating mixtures of substances can be created, which must be removed from the raw gas.

The application LAS provides **two filter solutions** for this with different prefilter combinations and an upstream expanded metal filter for precipitating the **aerosols and particles**. The expanded metal filter can be cleaned in an industrial washer and can thus be reused several times. Regularly changing the prefilter elements at shorter intervals significantly extends the functionality of the main filter.

Extremely fine suspended matter is retained by the High Efficiency Particulate Air filter H14 in the combined filter cassette H14A. This guarantees a **particle precipitation rate of 99.995%**.

The precipitation (adsorption) of **gaseous and vaporous** air pollutants takes place in the activated carbon bed of the combined filter cassette H14A.

The filter effect of the activated carbon is based on adsorption, i.e. on the adsorption of (gaseous) substances on the surface of the activated carbon. In general, no chemical changes of the adsorbed substance take place in physical adsorption. The nominal volumetric flow of the devices is based on the filter construction, the contact period is oriented to a medium adsorption response.

Thanks to the high degree of cleaning, **the filtered clean gas** can then be fed back into the working area (**recirculated-air** operation). This avoids any loss of heat.

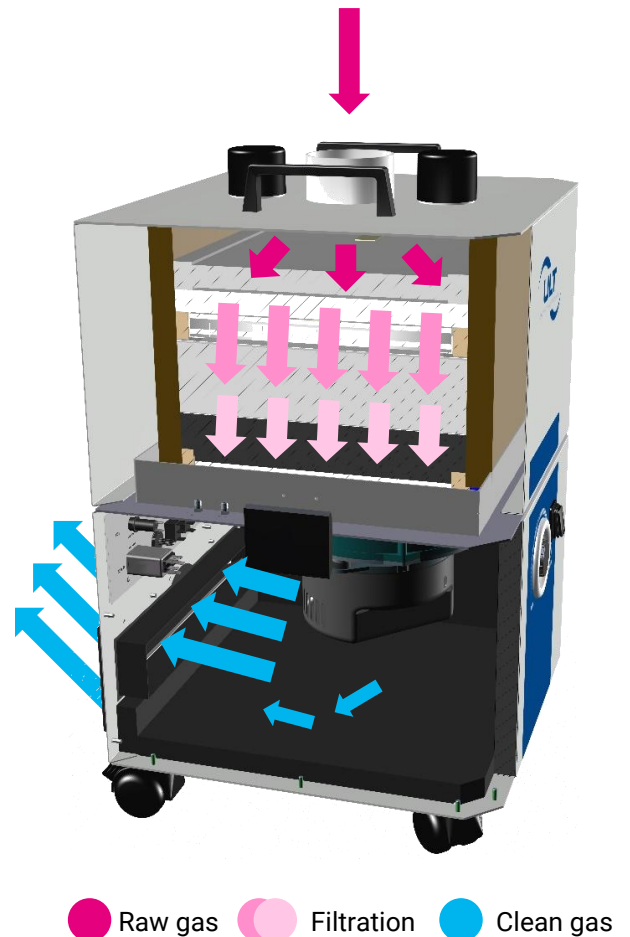

● Raw gas ● Filtration ● Clean gas



Recirculated air operation is not permitted for the suctioning and filtration of carcinogenic, mutagenic or reprotoxic substances. **The exhaust air spigot** that is included in the scope of delivery for the device is to be mounted on the blow-out side in such cases. The filtered clean gas must be channeled through a connected pipeline into a central discharge air system.

Device variants

A variety of filter combinations is available for the suctioning and filtration of harmful gas/dust mixtures from laser machining processes. The precipitation effectiveness of the available filter combinations depends on the machining process used. For expert advice when choosing the correct filter combination, please contact your local dealer or ULT AG directly using ult@ult.de.

In accordance with customer-specific requirement, the series ULT 200.1 devices can be equipped with the following filter attachments:

LAS 200.1 MD.20 K

A prefilter combination consisting of an upstream expanded metal filter, a filter mat and a panel filter retains aerosols and particles and prevents any premature clogging of the downstream H14 main filter element. This multi-level filter set-up is particularly suitable for the precipitation of **dry laser smoke**.

Table 8: LAS 200.1 MD.20 K

Part number of complete device:	1-00056
Filter set-up for laser smoke:	Main filter module K
(1) Expanded metal prefilter	Metal mesh, condensation filter
(2) Prefilter set	
(2.1) Filter mat G, coarse dust filter	Filter class: ISO Coarse 85% acc. to ISO 16890
(2.2) Panel filter F, fine dust filter	Filter class: ISO ePM1 70% acc. to ISO 16890
(3) Combined filter cassette H14A	
(3.1) Particulate filter H14	Filter class: H14 HEPA filter, suspended matter filter to DIN EN 1822
(3.2) Adsorption filter A	Filter medium: Activated carbon bed

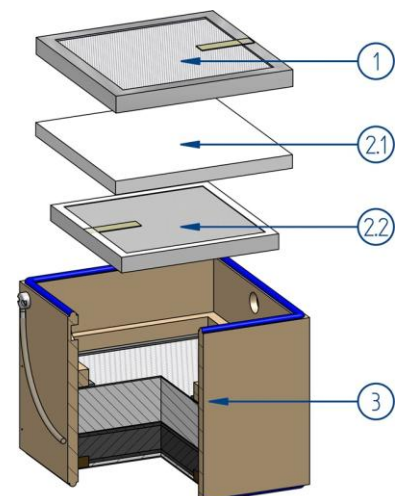



LAS 200.1 MD.20 TK

As an alternative, a device version is available in which a pocket filter is used for pre-precipitation. It is particularly suitable for processes in which large amounts of sticky laser smoke accumulates, e.g. from the processing of organic materials. Due to its very large volume, the pocket filter enables the condensation and agglomeration of the separated aerosols and particles without them blocking the filter.

Table 9: LAS 200.1 MD.20 TK

Part number of complete device:	1-00057
Filter set-up for laser smoke:	Main filter module TK
(1) Expanded metal prefilter	Metal mesh, condensation filter
(2) Pocket filter F, fine dust filter	Filter class: ISO ePM1 80% acc. to ISO 16890
(3) Empty frame for pocket filter	
(4) combined filter cassette H14A with filter mat	
(4.1) Filter mat G, filter protection	Filter class: ISO Coarse 85% acc. to ISO 16890
(4.2) Particulate filter H14	Filter medium: H14 HEPA filter, suspended matter filter to DIN EN 1822
(4.3) Adsorption filter A	Filter medium: Activated charcoal bed

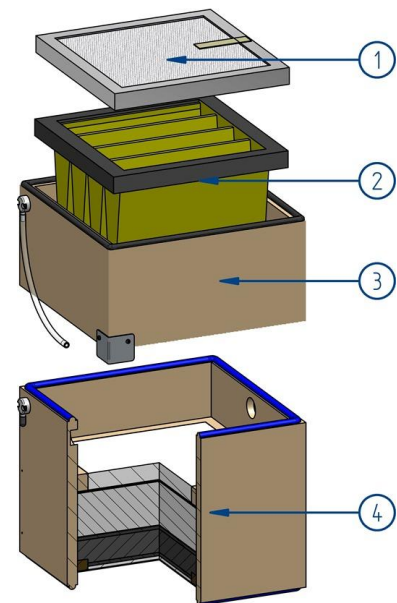



Application LRA – Soldering smoke

Areas of application

Manual Soldering | Robot Soldering | Soldering Systems at Special Workstations

Functional principle

An EC blower with a high pressure reserve generates a volumetric flow suitable for the application on the cleangas side of the filter. The volumetric flow can be controlled individually and steplessly. In this way, the pollutant-laden raw gas is extracted in a reliable manner.

When soldering work is performed, **soldering smoke** forms out of vaporizing flux, small quantities of solder and gas-emitting substances from working circuit boards and components. This is comprised of a mixture of adhesive aerosols, particles and gases that must be removed from the raw gas.

The filter set-up used is specially designed for this purpose. An upstream expanded metal filter holds back cooled, **sticky aerosols** in the suction line and prevents premature clogging of the subsequent filter elements.

The **particles** contained in the soldering smoke are precipitated in a multi-stage storage filter system. Thanks to their **depth penetration**, the filter mats used are particularly suitable for the precipitation of soldering smokes. A majority of the particles contained in soldering smoke and the aerosols still remaining in the raw gas are bonded at this stage. Extremely fine suspended substances are held back by the HEPA H13 filter in the combination filter cassette H13A. This guarantees a **particle precipitation rate of 99.95%**.

The precipitation (adsorption) of **gaseous and vaporous** air contaminations takes place in the activated carbon bed of the combined filter cassette H13A.

The filter effect of the activated carbon is based on **adsorption**, i.e. on the depositing of (gaseous) substances on the surface of the activated carbon. In general, no chemical changes of the adsorbed substance take place in physical adsorption. The nominal volumetric flow of the devices is based on the filter construction, the contact period is oriented to a medium adsorption response.

Thanks to the high degree of cleaning, the **filtered clean gas** can then be returned to the working area (**recirculated-air** operation). This avoids any loss of heat.

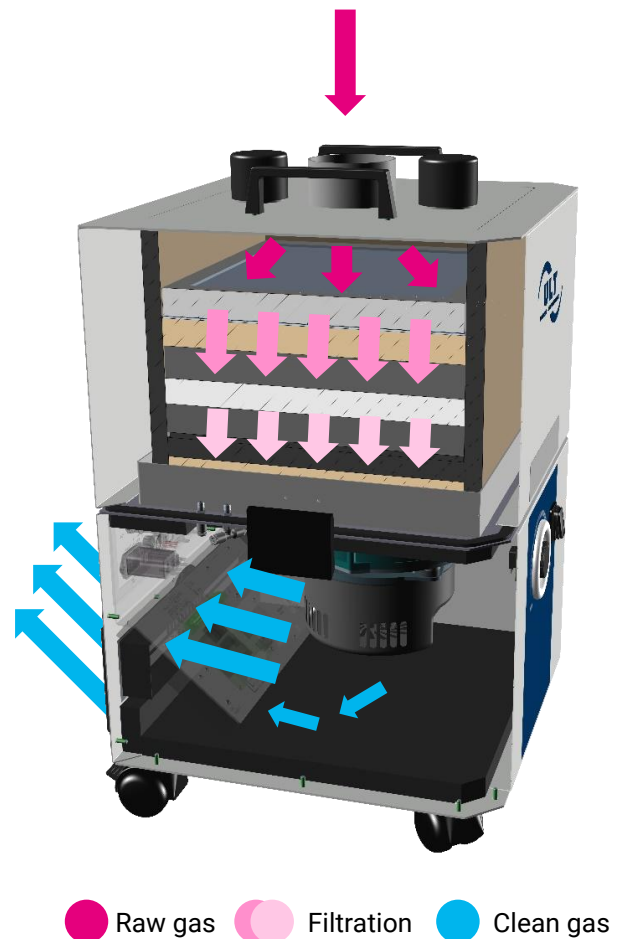



Recirculated air operation is not permitted for the suctioning and filtration of carcinogenic, mutagenic or reprotoxic substances. The **exhaust air spigot** that is included in the scope of delivery for the device is to be mounted on the blow-out side in such cases. The filtered clean gas must be channeled through a connected pipeline into a central discharge air system.

Device variants

The ULT 200.1 devices can be equipped with the following filter set-up for suctioning and filtering harmful gas/dust mixtures from soldering processes:

LRA 200.1 MD.20 K

Table 10: LRA 200.1 MD.20 K

Part number for complete device:	1-00088
Filter set-up for soldering smoke:	Main filter moule K
(1) Expanded metal prefilter	Metal mesh, condensation filter, spark protection
(2) Filter mats M5/F7	Filter classes: Filter mat M5: ISO Coarse 85% acc. to ISO 16890 Filter mat F7: ISO ePM10 75% acc. to ISO 16890
(3) combined filter cassette H13A	
(3.1) Particulate filter H13	Filter class: H13 HEPA filter, suspended matter filter to DIN EN 1822
(3.2) Adsorption filter A	Filter medium: Activated carbon bed

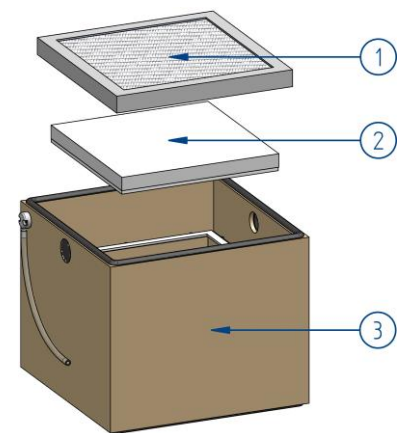



Accessory items

DN50 extraction system

Hoses



Flexible extraction hose DN 50, 2m	Antistatic, incl. 90° bend, socket and worm drive hose clips	3-00485
Flexible extraction hose DN 50, 3m	Antistatic, incl. 90° bend, socket and worm drive hose clips	3-00486
Flexible extraction hose DN 50, 5m	Antistatic, incl. 90° bend. socket and worm drive hose clips	3-00487
Flexible extraction hose DN 50, per meter	Antistatic, without accessories	6-06872

Hose accessories



Bend 90° DN 50	Antistatic, incl. worm drive hose clip	3-00494
Socket DN 50	Antistatic, incl. worm drive hose clip	3-00495
Y-piece DN 50 - 2*DN 50	Antistatic	6-06970

Extraction arm mounting elements



ULT 200.1 S50 console	Series 200.1 For Alsident System 50	3-00319
Table bracket black	Alsident System 50, accessory	2-5010-050

Extraction arms



Alsident system 50, antistatic extraction arm	945 mm for table/device mounting	50-4737-1-6
---	----------------------------------	-------------

Collecting elements



Flat screen antistatic	Alsident System 50, accessory	1-503324-6
Round hood aluminum antistatic	Alsident System 50, accessory	1-5024-6
Extractor tube antistatic	Alsident System 50, accessory	1-5021-6
Suction gap antistatic	Alsident System 50, accessory	1-5020-6



DN80 extraction system

Hoses



Flexible extraction hose DN 80, 2m	Antistatic, incl. 90° bend, socket and worm drive hose clips	3-00489
Flexible extraction hose DN 80, 3m	Antistatic, incl. 90° bend, socket and worm drive hose clips	3-00490
Flexible extraction hose DN 80, 5m	Antistatic, incl. 90° bend, socket and worm drive hose clips	3-00491
Flexible extraction hose DN 80, per meter	Antistatic, without accessories	6-06874

Hose accessories



Bend 90° DN 80	Antistatic, incl. worm drive hose clip	3-00496
Socket DN 80	Antistatic, incl. worm drive hose clip	3-00497
Reducer DN 80 - DN 75	Antistatic, for connecting a DN80 hose to the System 75 extraction arm, incl. worm drive hose clip	3-00499

Extraction arm mounting elements



ULT 200.1 S75 Console	Series 200.1 For Alsident System 75	3-00320
Table bracket white	Alsident System 75, accessory	2-7510

Extraction arms



Alsident system 75, extraction arm	1290mm for table/device mounting	75-6555-1-5
------------------------------------	----------------------------------	-------------

Collecting elements



Flat screen	Alsident System 75, accessory	1-753324-5
Round hood aluminum	Alsident System 75, accessory	1-7524-5
Extractor tube	Alsident System 75, accessory	1-7525



DN100 exhaust air extraction system

Hoses and hose accessories



Flexible extraction hose DN 100, per meter	Antistatic, without accessories	6-06875
Socket DN 100	Antistatic, incl. worm drive hose clip	3-00500

Interface accessories

M12 interface accessories



M12 connection cable	incl. M12 Male adapter, length 3m	3-00234
M12 On/Off foot switch	incl. M12 Male adapter, length 3m	3-00235

Device power cables – supplied free of charge with ordered device



Swiss device power cable	Length 3.00 m	6-06056
UK device power cable	Length 2.00 m	6-06063
USA device power cable	Length 2.00 m	6-06091
EU device power cable (CEE 7/7) - included as standard	Length 3.00 m	6-05990

Secondary filter U15



LAS 200.1 secondary filter module U15	Retrofit kit for exhaust air filtration	3-01160
Particle filter U15	For secondary filter	6-11662



Replacement filter

ACD

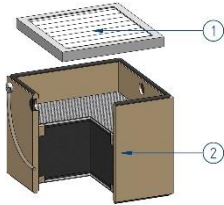

Filter A6

G4 Z-Line filter

4-00299

Adsorption filter cassette A6

4-00389

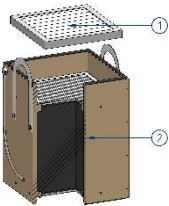

Filter A14

G4 Z-Line filter

4-00299

Adsorption filter cassette A14

4-00391

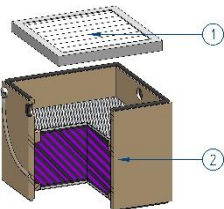

Filter AC7

G4 Z-Line filter

4-00299

Chemisorption filter cassette AC7

4-00393

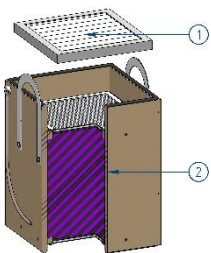

Filter AC17

G4 Z-Line filter

4-00299

Chemisorption filter cassette
AC17

4-00418

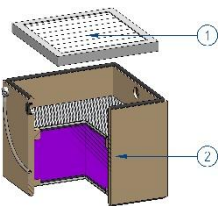

Filter C11

G4 Z-Line filter

4-00299

Chemisorption filter cassette C11

4-00403

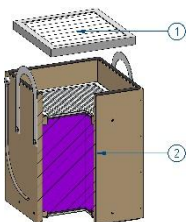

Filter C20

G4 Z-Line filter

4-00299

Chemisorption filter cassette C20

4-00413



ASD

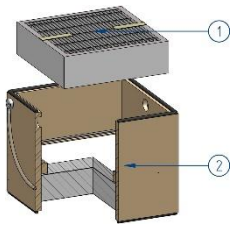

Filter H

Panel filter F - set of 5 pcs	4-00309
-------------------------------	---------

Particle filter cassette H14	4-00073
------------------------------	---------

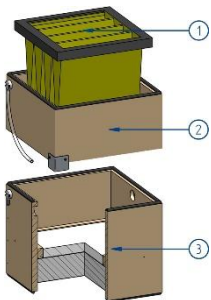

Filter TH

Pocket filter F - set of 5 pcs	4-00198
--------------------------------	---------

Empty frame for pocket filter	4-00079
-------------------------------	---------

Particle filter cassette H14	4-00073
------------------------------	---------

LAS

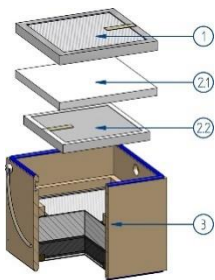

Filter K

Expanded metal filter	4-00301
-----------------------	---------

Prefilter set LAS K - set of 5 pcs	4-00604
------------------------------------	---------

Combined filter cassette H14A	4-00076
-------------------------------	---------

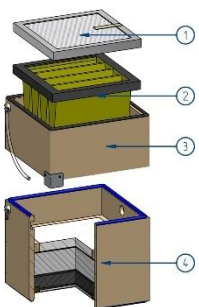

Filter TK

Expanded metal filter	4-00301
-----------------------	---------

Pocket filter F - set of 5 pcs	4-00198
--------------------------------	---------

Empty frame for pocket filter	4-00079
-------------------------------	---------

Combined filter cassette H14A + mat	4-00080
-------------------------------------	---------

LRA

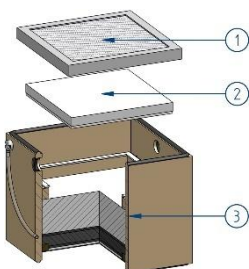

Filter K

Expanded metal filter	4-00301
-----------------------	---------

Filter mat M5-02/F7-02 - set of 10	4-00241
------------------------------------	---------

H13A combined filter cassette	4-00075
-------------------------------	---------

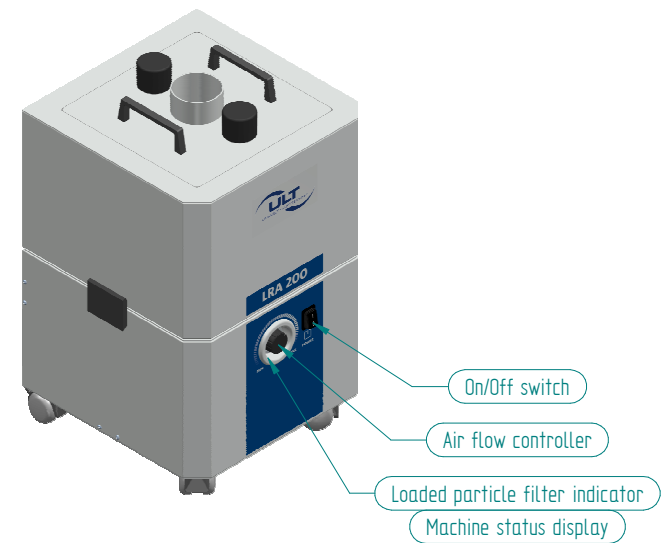
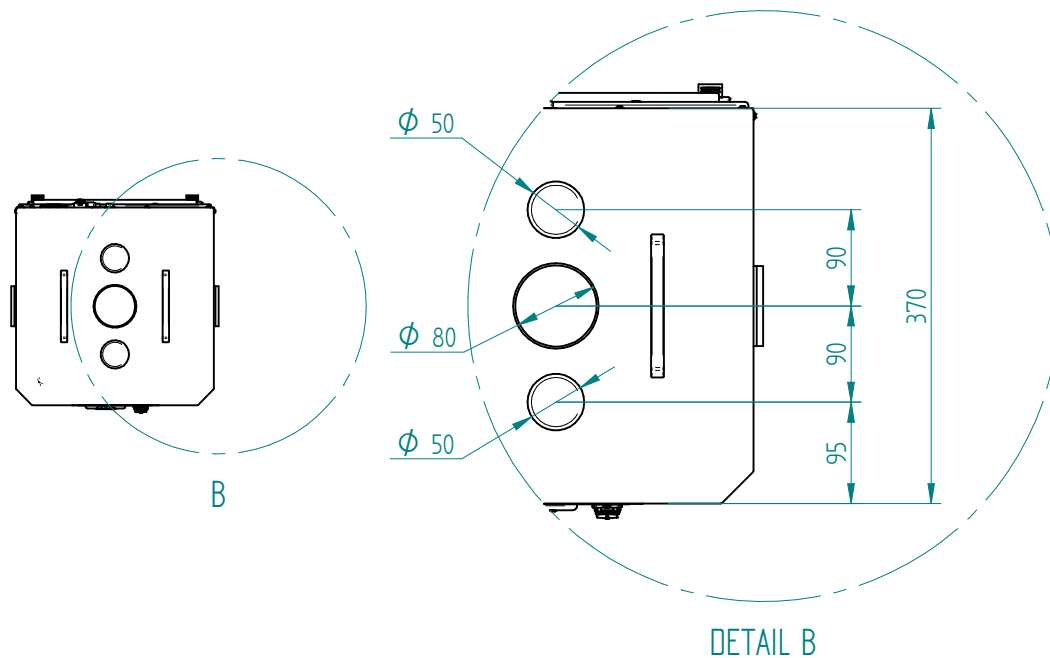
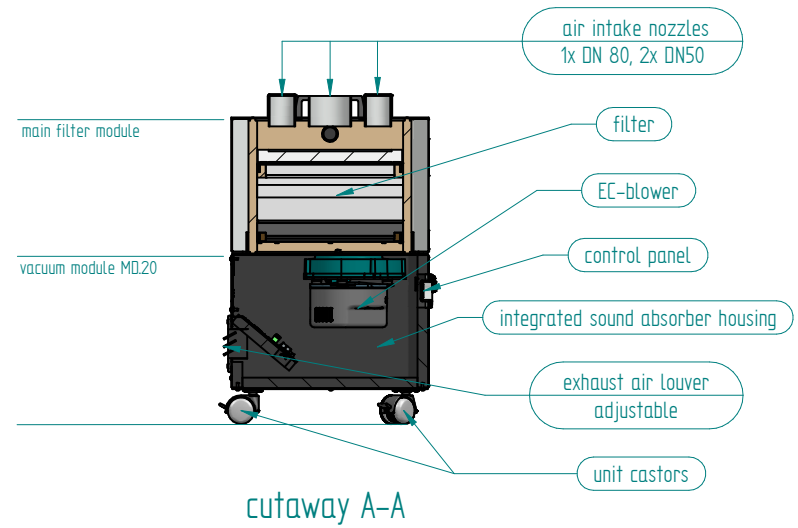
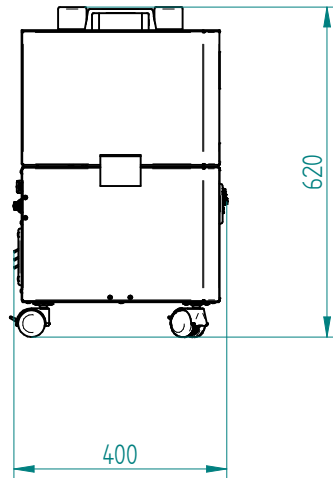
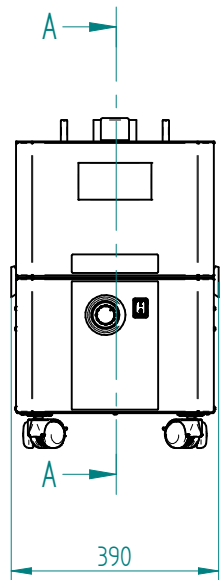

Weitere Maße sind dem 3D-Datensatz zu entnehmen. Für die Zeichnung behalten wir uns alle Rechte vor.
Other measure are to be taken from the 3D record. For the drawing we reserve ourselves all rights.

				ULT AG		designation	
				Am Gopelreich 1		ULT 200.1 MD.20 M	
				D-02708 Lobau			
				2018		date	
				JSACZ		name	
001		21.02.18		edit.		drawing number:	
issue		revision		day		2017050500003	
				name		scale:	
				Norm		1 : 10	



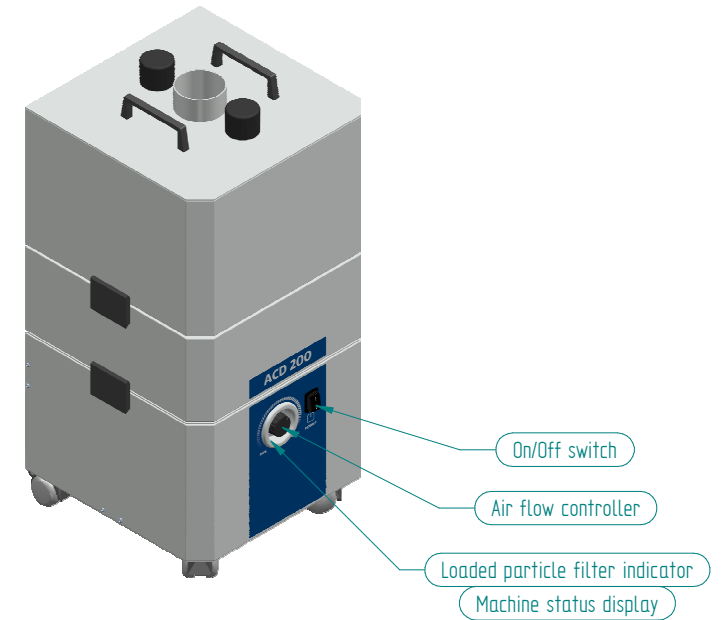
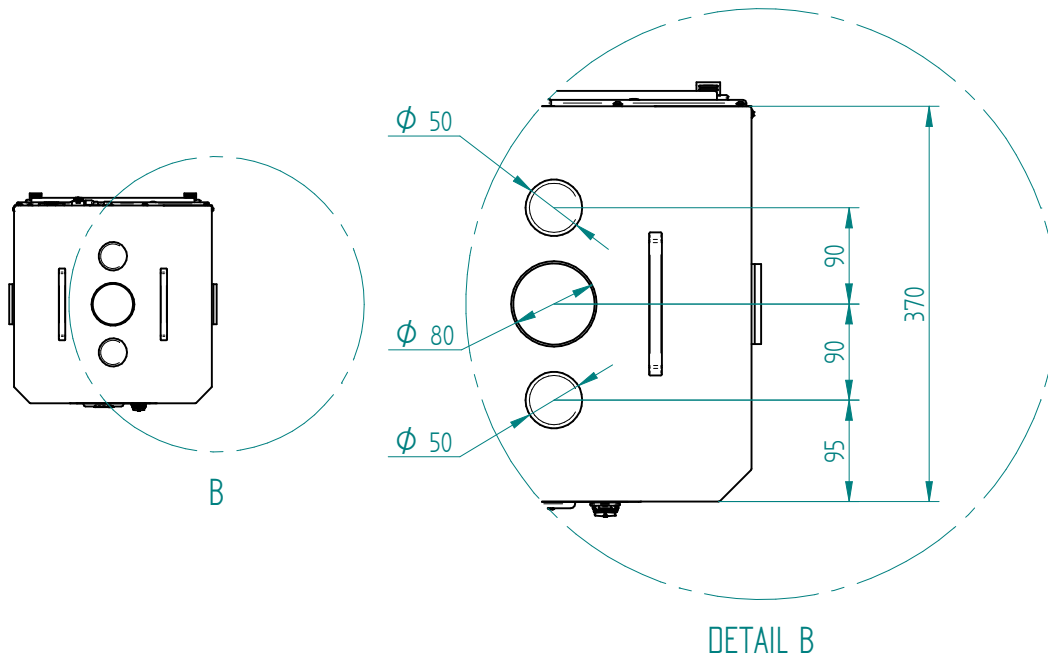
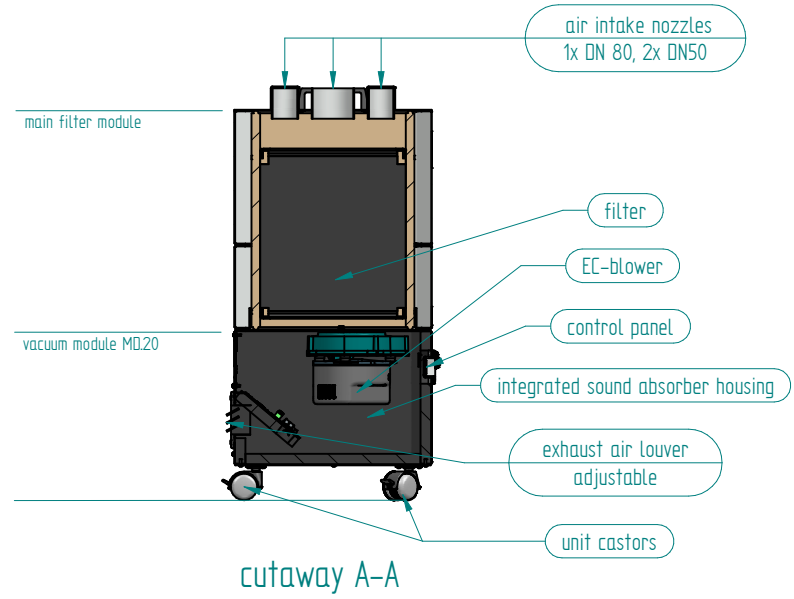
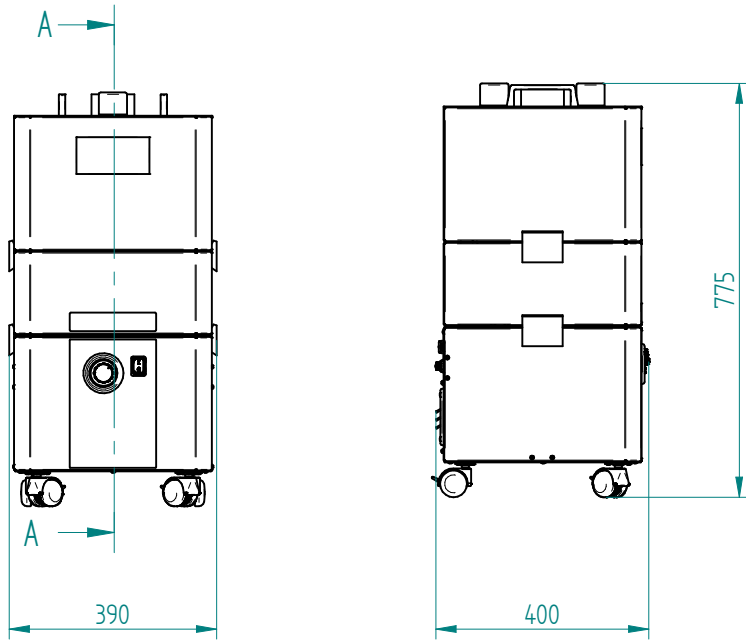

Weitere Maße sind dem 3D-Datensatz zu entnehmen. Für die Zeichnung behalten wir uns alle Rechte vor.
Other measure are to be taken from the 3D record. For the drawing we reserve ourselves all rights.



				ULT AG Am Göpelteich 1 D-02708 Lobau		designation: ULT 200.1 MD20 L	
				2018	date	name	
001	base	14.03.18	JSACZ	edit.	14.03.	JSACZ	drawing number: 2017050500003
issue	revision	day	name	verf.			scale: 1 : 10
				Norm			

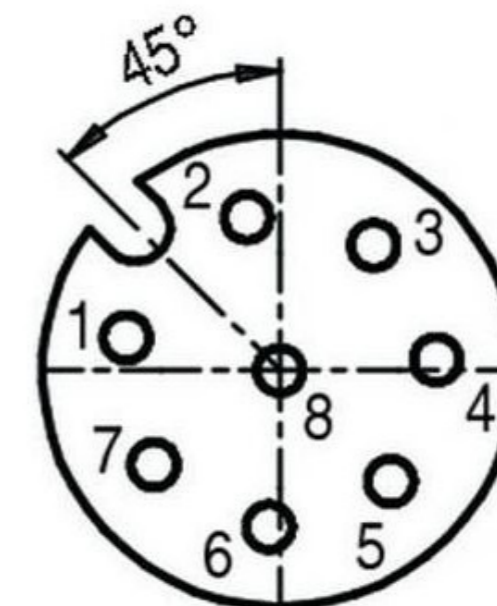
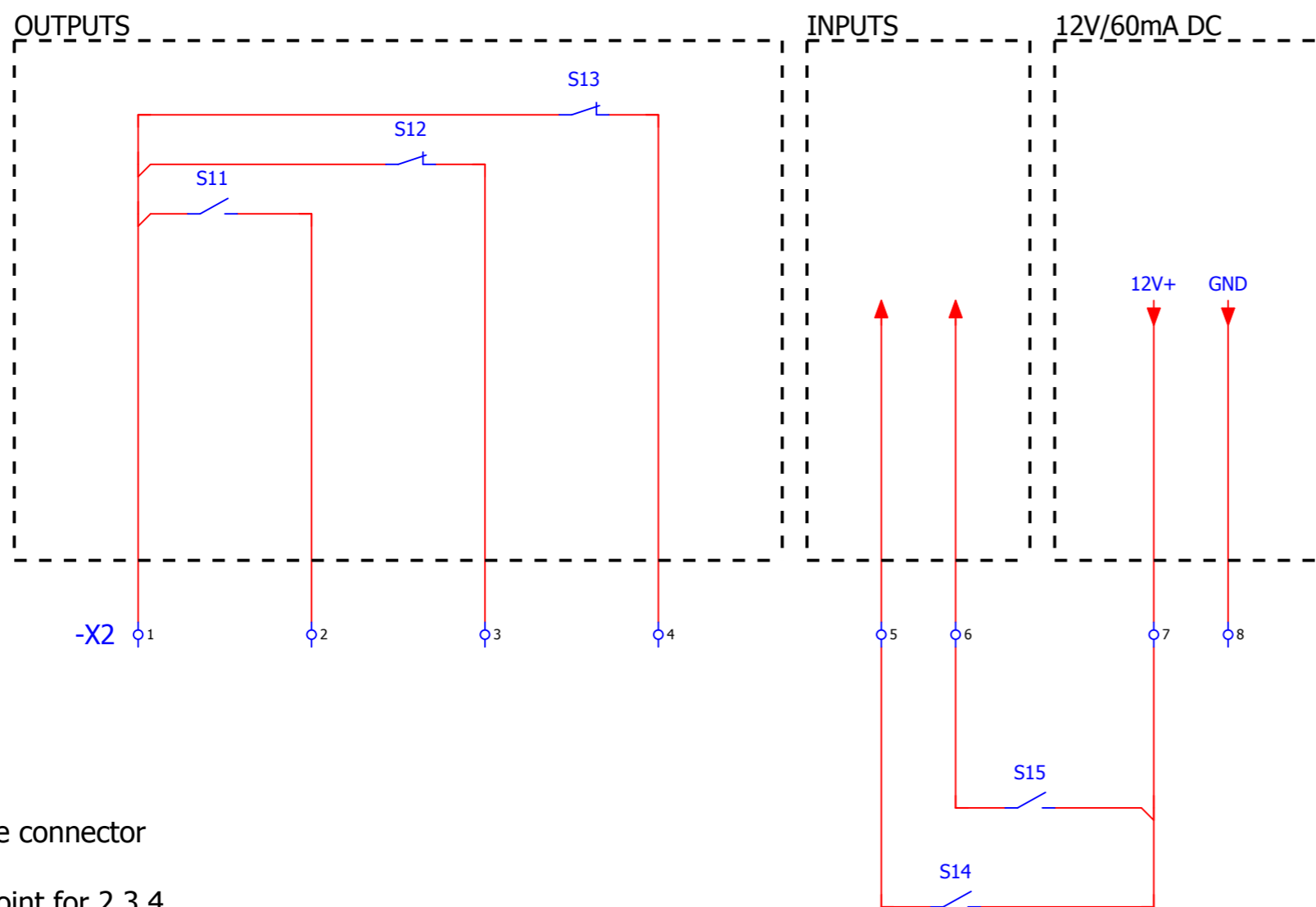

-X2 M12 8-pole female connector

- 1: Common contact point for 2,3,4
- 2: Potential free contact 30V/100mA - NO - operation message (1)
- 3: Potential free contact 30V/100mA - NC - filter nearly full (1)
- 4: Potential free contact 30V/100mA - NC - filter completely full (1)

- 5: Remote control input 12V/5mA (2)
- 6: Filter cleaning trigger 12V/5mA (2)

- 7: 12V output, maximal rating 60mA
- 8: GND

Note (1): Signals are only to be evaluated when the unit is connected to supply voltage and the main switch is ON

Note (2): Can be triggered from 7 (represented by S14, S15) or with external voltage up to 24V (GND of the external voltage source has to be connected to contact 8)

Datum	21.03.2019
Bearb.	EV
Gepr	
Änderung	Datum
	Name

ULT200.1 MD20

ULT AG
Am Göpelteich 1, 02708 Löbau
Telefon: +49 (0) 3585-4128-0
Email: ult@ult.de



M12 Schnittstelle

ULT 200.1 MD 20, M12 8PIN

ULT200.1_60_000

Blatt 112

Seite 12 / 13

ULT AG

Am Göpelteich
02708 Löbau
Germany

Phone: +49 3585 4128 0
Fax: +49 3585 4128 11
E-Mail: ult@ult.de
Web: www.ult.de



air quality