



Class H-certified



ATEX
compliant



Free of ignition
sources



Technical documentation

LAS 260 MD.20 K H/Ex

Version 006



air quality



Contents

Description of product series	3
Features – LAS 260 H/Ex extraction and filtration unit.....	4
Equipment.....	5
Technical data	6
LAS 260 MD.20 K H/Ex	6
Characteristic curve (230 V).....	7
LAS series – laser smoke.....	8
Areas of application	8
Operating principle	8
Filter layout – LAS 260 MD.20 K H/Ex	9
Accessory items	10
Suction system DN50.....	10
Interface accessories.....	11
Replacement filters	11
Personal grounding kit	11
Attachments:	
• Drawing	
• Interface diagram M12	
• ATEX Declaration of Conformity	



Description of product series

The **LAS 260 H/Ex** is designed to be **free of ignition sources**. It is a device for extraction and filtration of dry and combustible harmful substances (dust and smoke) that can be produced during laser machining of plastics and metals. In addition, the LAS 260 H/Ex is also designed to be installed and operated within a **zone 22 area (ATEX compliant)** and enables safe separation of carcinogenic dusts (**class H-certified**).

A 2-stage filter system is available **for industrial applications** involving substances with increased requirements in relation to health protection and explosion protection.

The harmful and unwanted substances produced in the relevant customer process are collected via a collection element and filtered in the **LAS 260 H/Ex**. When the raw gas enters the device, finest suspended solids are retained by the **HEPA H14 filter** in the main filter stage. This guarantees a **particle separation rate of 99.995%**. The device is equipped with a safety filter stage with integrated activated carbon fill, which follows after the main filter. The **safety filter** ensures safe operation of the device and prevents carryover between Ex-zones.

Thanks to the high degree of purification, the filtered clean gas can be directed back into the working space (**recirculated air mode**).

Specific characteristics for CMR substances:

The **LAS 260 H/Ex** is certified in accordance with EN 60335-2-69 as a Class H* dust extractor for the separation of all types of dusts with all exposure limits, including dusts containing carcinogenic or pathogenic particles. Consequently, extraction and filtration of substances that are carcinogenic, mutagenic, or toxic for reproduction (CMR substances) is possible in recirculated air mode.

* Tested and certified by ILK Dresden (Institute of Air Handling and Refrigeration)

“Ex” labeling / specific characteristics for combustible dust:



II3/3D tc IIIC T6 Dc

Extraction of dust that is not capable of self-ignition and has a minimum ignition energy of > 10 mJ is permitted provided the following requirements are met:

- The flow velocity along the entire intake section must be > 20 m/s.
- The possibility of sparks being sucked into the device must be ruled out.
- Regular filter change intervals – at the latest when saturation is indicated – must be ensured.



Features – LAS 260 H/Ex extraction and filtration unit

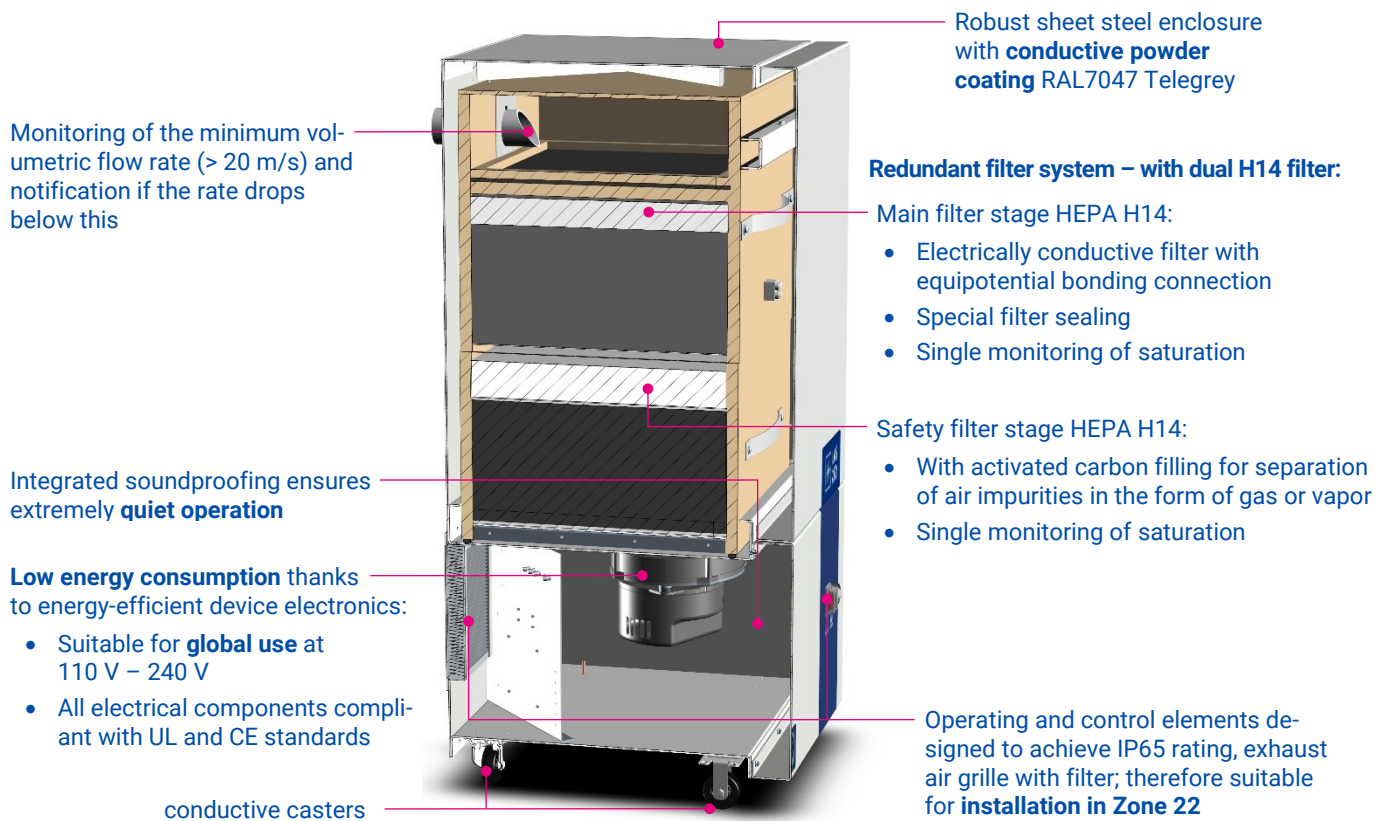



Equipment

Figure 1: Front operating panel

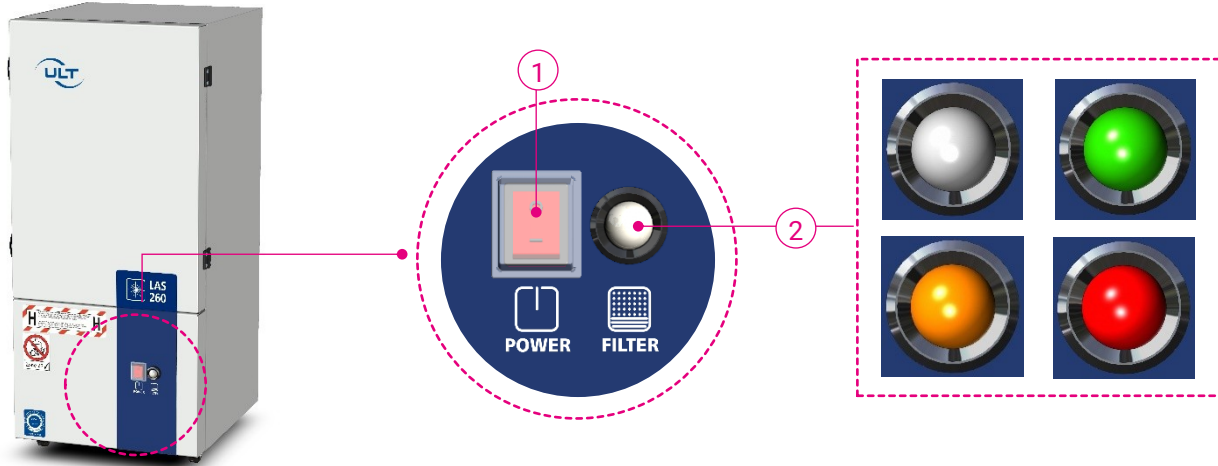

1 ON/OFF switch

2 LED status light

- Operating status indicators
 - Standby mode via remote control (white)
 - Normal operation (green)
 - Malfunction due to error condition (red flashing)
- Particulate saturation indicator
 - Main filter OK (green)
 - Main filter nearly saturated (orange)
 - Main filter fully saturated (red)

Figure 2: Interfaces on the rear

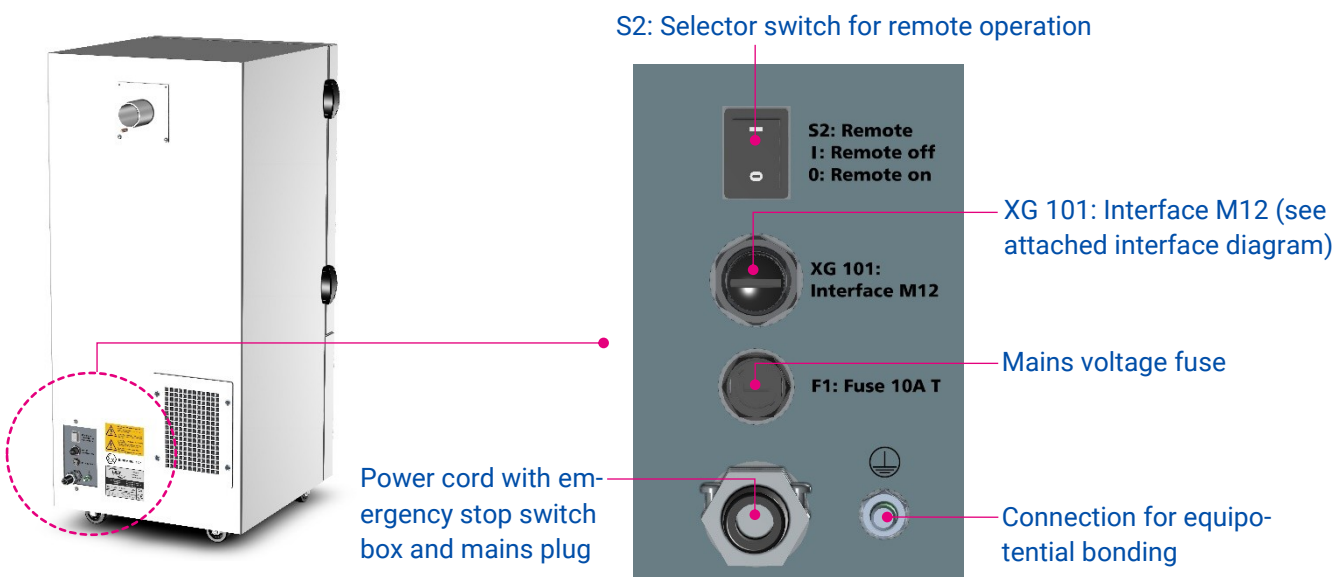



Technical data

LAS 260 MD.20 K H/Ex

PARAMETER	UNIT		
Max. volumetric flow rate	m ³ /h	360	
Max. vacuum	Pa	9,500	
Rated volumetric flow rate (fan characteristic curve)	m ³ /h @ Pa	200 @ 5,000	
Protection rating	IP	65	
Sound level (@ 50% - 100% volumetric flow rate)	dB(A)	47 - 60	
Vacuum generator type		EC blower	
Rated motor power	W	750	
Rated voltage	VAC	1~110 ... 240	
Rated frequency	Hz	50/60	
		Voltage level 120 V	Voltage level 230 V
Rated current	A	9.2	5.3
Volumetric flow rate controller		No	
Particulate filter saturation indicator	Visual	Yes	
Interface M12		Yes	
Dimensions (width x depth x height)	mm	470 x 550 x 995	
Weight (without filter)	kg	Approx. 60	
Max. weight with filter	kg	Approx. 82	
Air intake variants:	Intake nozzle	1x Ø 50 mm on rear at top	
	Connection options	Hose connection	
Outlet air guidance:		Outlet grille with filter on rear at bottom	
Mains connection		Fixed connection on the device, cable length 5.0 m with EU plug (CEE 7/7 / other country-specific variants can be chosen)	



Characteristic curve (230 V)

Figure 3: Characteristic curve (230 V)

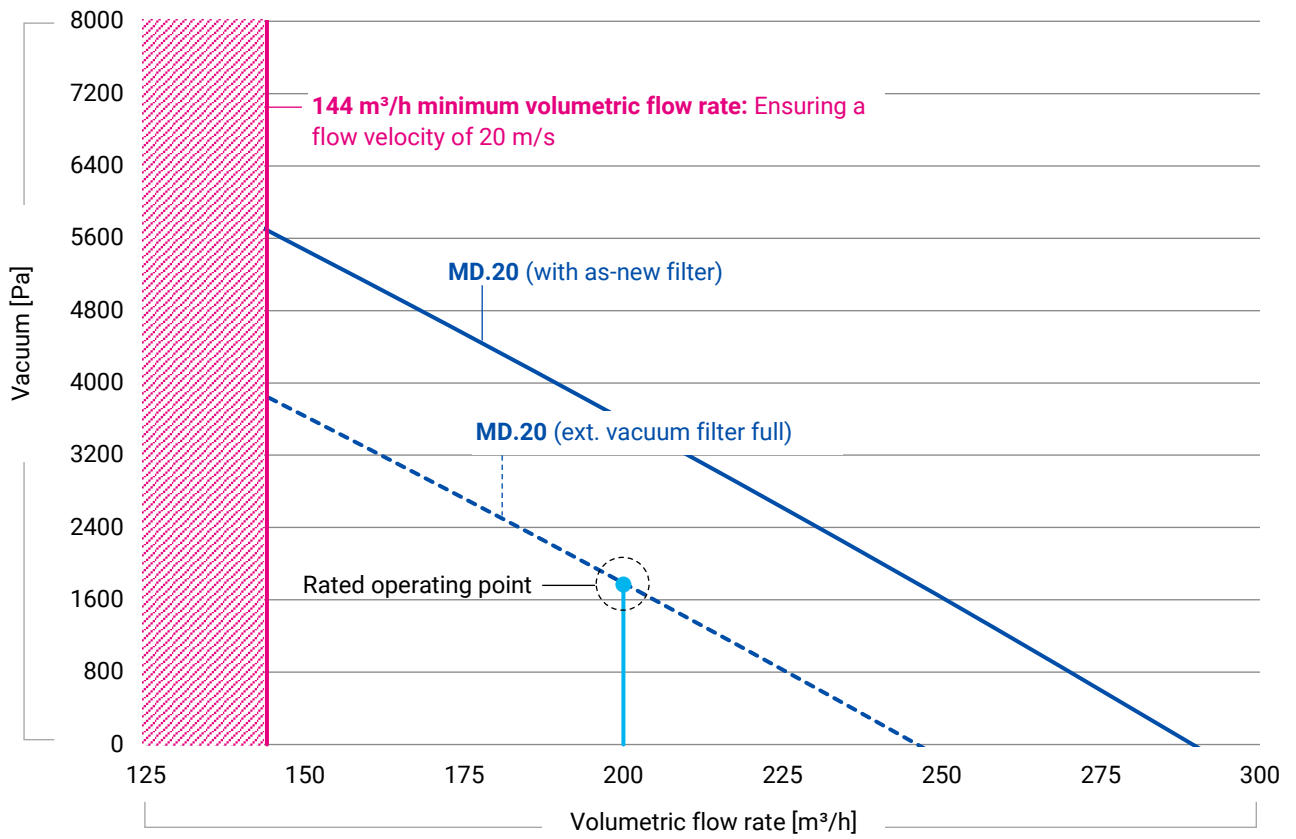



LAS series – laser smoke

Areas of application

Laser cutting | Laser marking | Laser structuring | Laser engraving

Operating principle

The blower installed in the LAS 260 MD.20 K H/Ex generates a negative pressure (vacuum) at the intake nozzle of the connected collection element. As a result, impurities in the air can be collected and sucked out directly at the point of creation.

All components of the device that are in direct contact with the raw gas (filter, housing) are integrated in an equipotential bonding system to prevent any electrostatic discharge. The device is equipped with a two-stage filter system.

When the **raw gas** enters the device, all collected **particles** are retained by the HEPA H14 filter in the filter cassette of the main filter stage. This guarantees a particle separation rate of 99.995%.

The subsequent safety filter stage is equipped with a further HEPA H14 filter and an integrated activated carbon fill. This redundant use of a second H14 filter ensures safe and fault-free operation. Carryover between Ex-zones is prevented. The saturation status of the safety filter is monitored using a differential pressure sensor.

The separation (adsorption) of air impurities in the form of **gas or vapor** takes place in the activated carbon fill of the safety filter. The filtration effect of the activated carbon is based on adsorption, i.e. the process by which (gaseous) substances adhere to the porous surface of the activated carbon. Here, physical adsorption does not involve any chemical changes to the substance being adsorbed.

Thanks to the high degree of purification, the **filtered clean gas** can be directed back into the working space (recirculated air mode). As a result there are no thermal losses. Since the LAS 260 MD.20 K H/Ex is a certified* dust extractor for dust class H (EN 60335-2-69), the filtered clean gas can also be fed back into the working space in applications where CMR substances are being extracted.

Figure 4: Filtration in the device

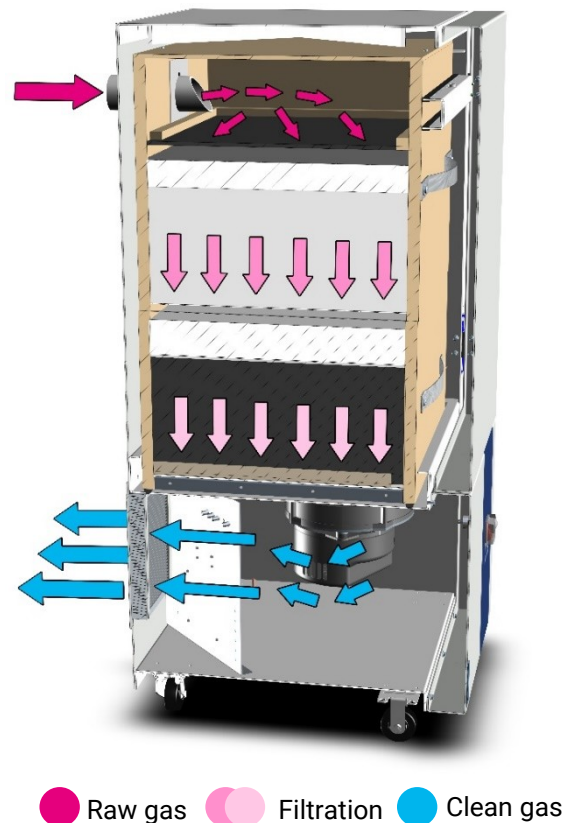

* Tested and certified by ILK Dresden (Institute of Air Handling and Refrigeration)



Filter layout – LAS 260 MD.20 K H/Ex

Table 1: LAS 260 MD.20 K H/Ex

Product number for the complete unit: 1-00140	
Filter configuration for laser smoke:	
Main filter (particulate filter cassette H14)	4-00633
(1) Raw gas intake	
(2) Particulate filter H14	
Filter class:	H14 HEPA filter, particulate air filter in acc. with EN 1822
Safety filter (combined filter cassette H14A10)	4-00632
(3) Particulate filter H14	
Filter class:	H14 HEPA filter, particulate air filter in acc. with EN 1822
(4) Adsorption filter A10	
Filter medium:	Activated carbon fill, 10 kg

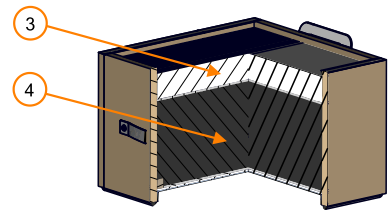
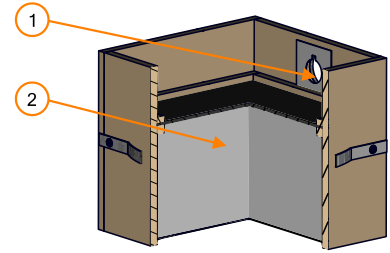



Accessory items

Suction system DN50

Hoses



Suction hose DN50 Sold by the meter	Electrically conductive	6-06856
--	-------------------------	---------

Hose accessories



Spiral clamp 45-65 mm	Integrated grounding	6-06964
-----------------------	----------------------	---------

Elements for installation of the extraction arm – for use outside of zone 22



Tabletop stand, black	Alsident system 50, accessories	2-5010-050
-----------------------	---------------------------------	------------

Extraction arms – for use outside of zone 22



Alsident System 50, Extraction arm	945 mm For tabletop/device mounting	50-4737-1-6
---------------------------------------	--	-------------

Collection elements – for use outside of zone 22



Flat hood, antistatic	Alsident system 50, accessories	1-503324-6
Round hood, aluminum, antistatic	Alsident system 50, accessories	1-5024-6
Suction tip, antistatic	Alsident system 50, accessories	1-5021-6
Suction nozzle, antistatic	Alsident system 50, accessories	1-5020-6



Interface accessories

Accessories for interface M12



Connecting cable M12

Incl. M12 adapter,
Length 3 m

3-00234



Foot switch ON/OFF M12

Incl. M12 male adapter,
Length 3 m

3-00235

Replacement filters

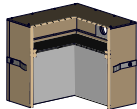

Particulate filter cassette H14

4-00633

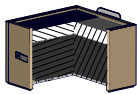

Combined filter cassette H14A10

4-00632

Personal grounding kit



Personal grounding kit

Grounding wristband with spiral
cable, 1.8 m, snap fastener

3-01186

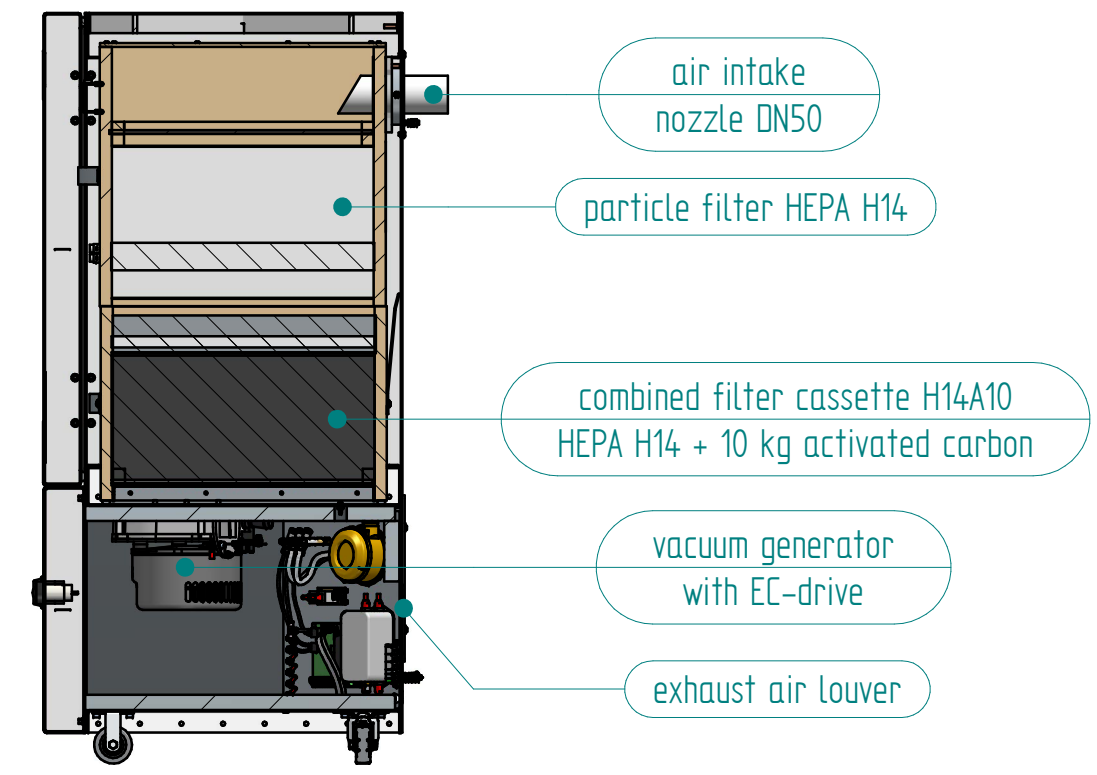
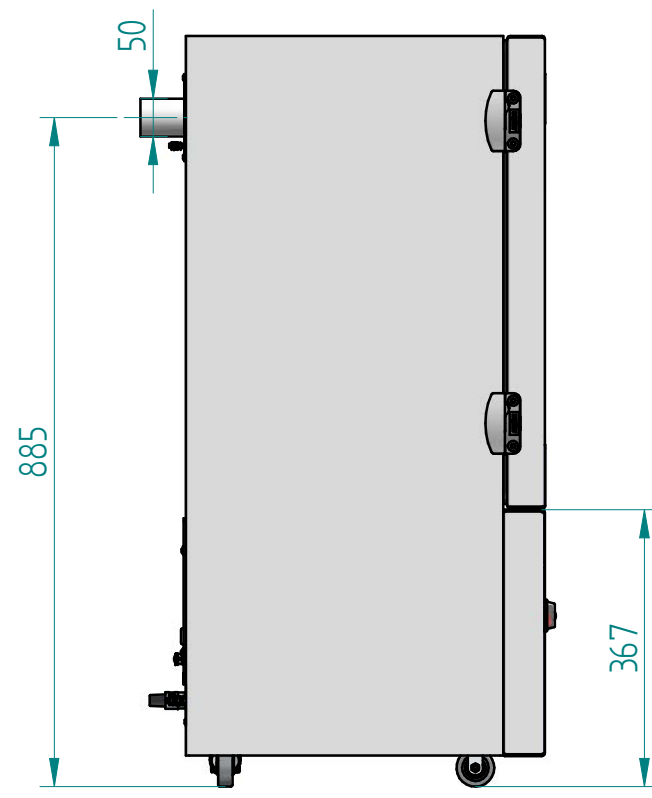
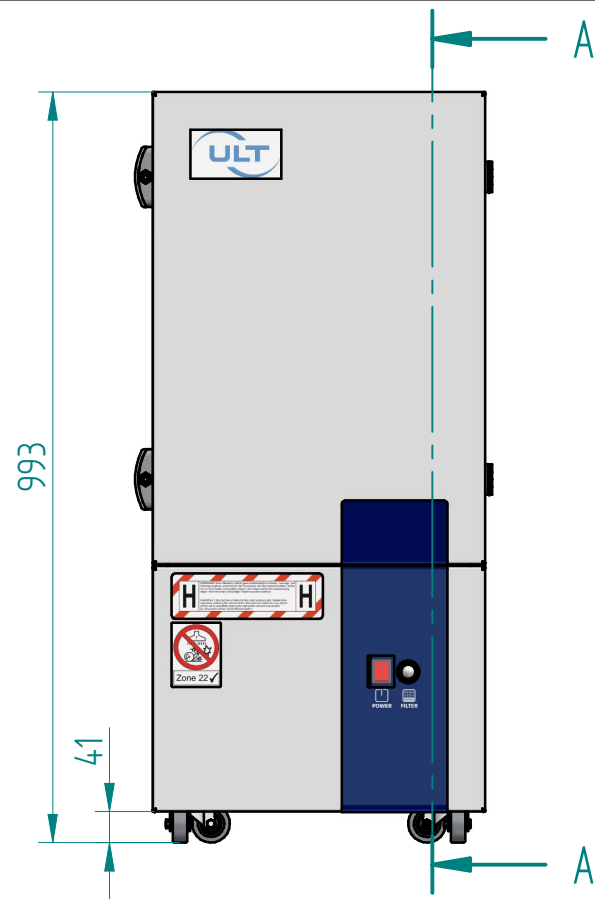

cutaway A-A

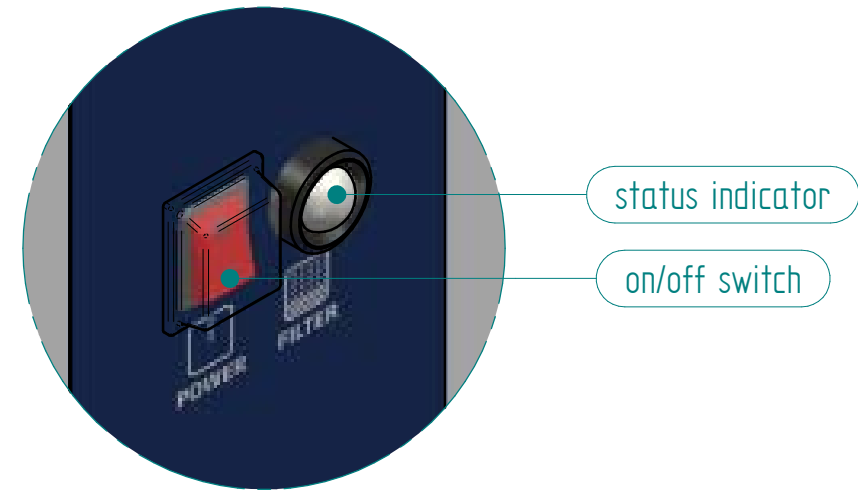
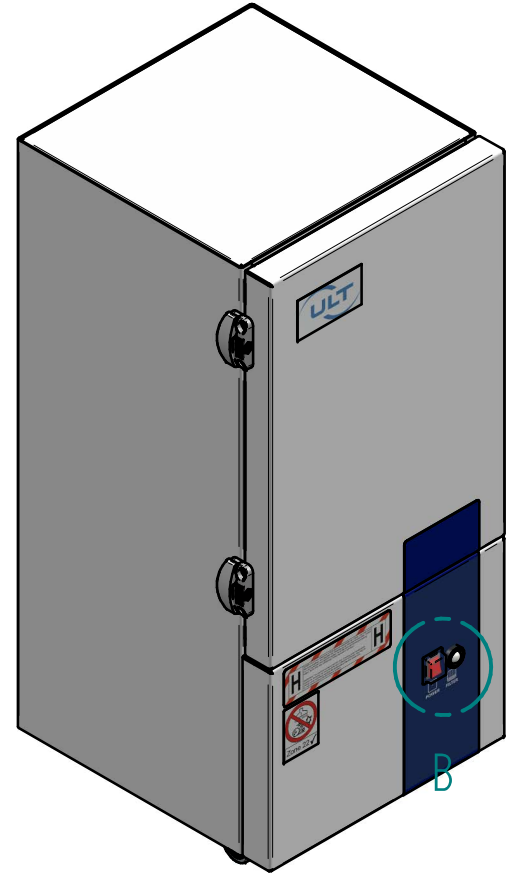
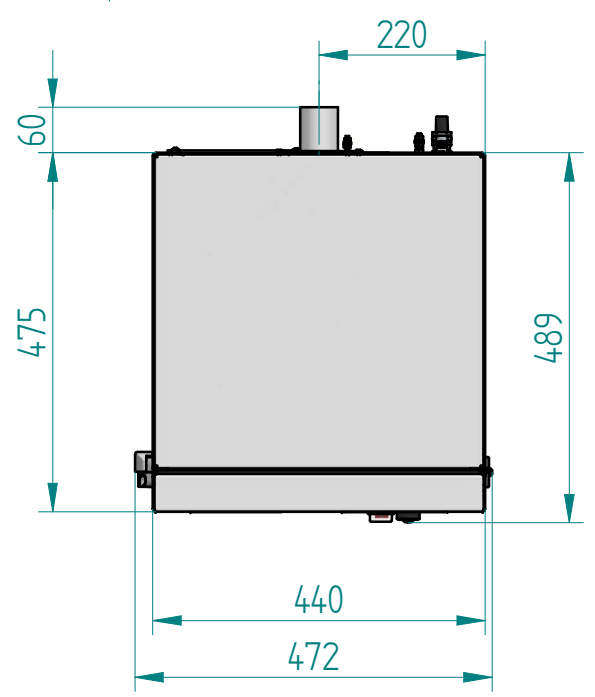

DETAIL B

Latest Revision
 Index

Revision				
Index	Description	Sheet	Date	Name
000	Basis			

Department Konstruktion	Technical Reference ULT AG Am Göpelteich 1 D-02708 Löbau	Document Status Verfügbar	Gewicht 0 kg	Created by B.Jüngling	Created on 13.10.2023
 Copyright as per ISO 16016.		Title / Supplementary Title LAS 260 H/Ex		Approved by Approved on	
		Identification Number ULT260_00_051	Revision 000	Language EN	Scale 2:1

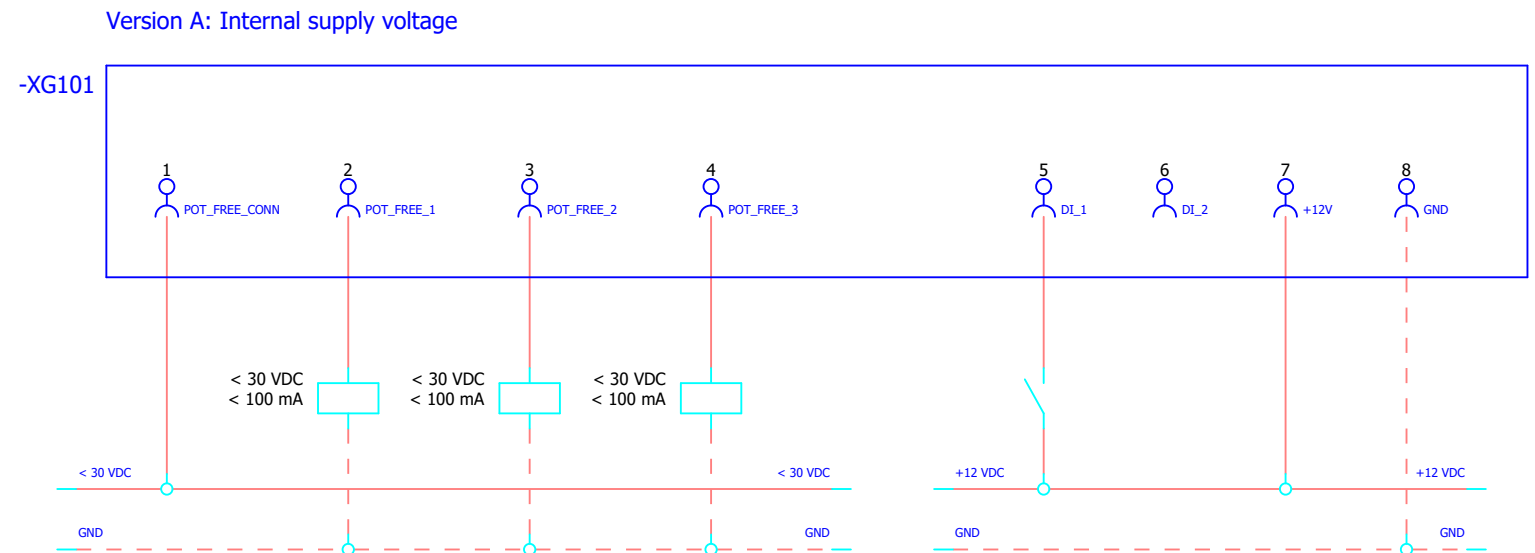

XG101 DIN EN 61076-2-101 / M12 / A-encoded / 8-pole / socket					
PIN	Function	Potential	Rating	Status	Description
1-2	Operating status (1)	Potential-free	< 30 VDC < 100 mA	Open	Machine not running
				Closed	Machine running
1-3	Filter status (1)	Potential-free	< 30 VDC < 100 mA	Open	Filter 80% used up
				Closed	Filter OK
1-4	Filter status (1)	Potential-free	< 30 VDC < 100 mA	Open	Filter 100% used up
				Closed	Filter OK
5-7	Remote ON/OFF (2)	12 VDC	12 VDC	High	Maschine ON
				Low	Maschine OFF

- Note (1): Evaluation of the signals is only permitted if the machine is connected to the power supply and switched ON.
- Note (2): Actuation of Remote ON/OFF only via internal supply voltage (pin 7).
- Note (3): Actuation of potential-free contacts only via the supply voltage on the operator's side (max. 30 VDC).
- Note (4): Allow for a 10-second lead time: The LAS 260 must be switched on 10 seconds before the start of the machining process to ensure that the required flow velocity of 20 m/s is attained in the suction line up to the collection point.

ULT AG
Am Göpelteich 1
OT Kittlitz
D-02708 Löbau



EU - Declaration of Conformity

according to Directive 2014/34/EG (ATEX)

Herewith, we declare that the following product type in its delivered state complies with the following relevant provisions:

ATEX directive 2014/34/EG
Electromagnetic compatibility - directive 2014/30/EU

If the above mentioned machine is technically modified without our approval, this declaration shall no longer be applicable:

Description of machine: extraction and filtering unit

Machine type: LAS 260 MD.20 K H/Ex

Identification: ⊕ II3/3D tc IIIC T6 Dc

Series No.: JJJJ 67 xxxx
(Year - Type/Serial - Number)

Applied national technical standards and specifications:

DIN EN ISO 12100: 2010
DIN EN 60204-1: 2019
DIN EN 61000-6-2: 2019
DIN EN 1127-1: 2019
DIN EN ISO 80079-36: 2016
IEC 60079-0: 2019
DIN EN 60079-31: 2014
IEC 62784:2017
IEC 60335-2-69:2021

Karl Ullwer is the authorized representative for completion of the technical documentation

Adress: ULT AG
Karl Ullwer
Am Göpelteich 1
D-02708 Löbau

place, date: Löbau, 14.03.2024

signature:

Dr. S. Jakschik / MD

ULT AG
Am Göpelteich 1 - OT Kittlitz
D - 02708 Löbau
Telefon +49 (0)3585 / 41 28 - 0
Telefax +49 (0)3585 / 41 28 11
ult@ult.de · www.ult.de

ULT AG

Am Göpelteich 1
02708 Löbau
Germany

Phone: +49 3585 4128-0
Fax: +49 3585 4128-11
E-mail: ult@ult.de
Website: www.ult.de



air quality